



Operator's Manual

DWT085D3-300V Thruster

DWTEK Co., Ltd

No.22, Dong Ying Rd., East District, Taichung City 401, TAIWAN

T: +886-4-3502-4890 | E: info@dwtek.com.tw

F: +886-4-2211-2890 | W: www.dwtekmarine.com

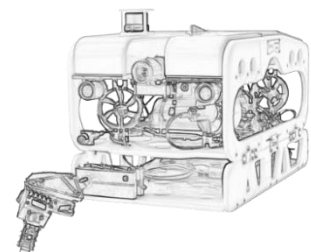



Table of Contents

1	Introduction	5
1.1	General.....	5
1.2	Precautions	6
2	Specifications.....	7
2.1	Thruster	7
2.2	Connector.....	9
2.2.1	General.....	9
2.2.2	Indications for Replacement	9
2.2.3	Cleaning Procedure.....	9
3	Installation.....	10
3.1	Installation Guide.....	10
3.2	Pin Assignment	10
3.3	Maintenance and Removal.....	13
4	Trouble shooting	14
4.1	Thruster Trouble shooting	14
4.2	Detection Procedure.....	14
5	Maintenance	15
5.1	Nozzle	15
5.1.1	General.....	15
5.1.2	Indications for Replacement	15
5.1.3	Removal the Nozzle from Thruster `	15
5.2	Propeller Assembly	16
5.2.1	General.....	16
5.2.2	Indications for Replacement	16
5.2.3	Removal Procedures	16
5.2.4	Install Procedures	16
6	Oil Filled and Drain.....	17
7	Appendix.....	23
7.1	Vacuum and Pressure Relief	23
7.2	Spares and Tools.....	24
7.3	Exploded View.....	25
7.4	PWM Signal Control	28



List of Figures

Figure 1 - DWT085D3 Thruster	7
Figure 2 - DWT085D3 Thruster performance curve	8
Figure 3 – DWT085D3 Thruster Pin Assignment	11
Figure 4 - Oil Filled-1	18
Figure 5 - Oil Filled-2	18
Figure 6 - Oil Filled-3	19
Figure 7 - Oil Filled-4	19
Figure 8 - Oil Filled-5	20
Figure 9 - Oil Filled-6	20
Figure 10 - Drain Procedure-1	22
Figure 11 - Drain Procedure-2	22
Figure 12 - DWT085D3 Thruster (2B0040007-00002).....	25
Figure 13 – End Cap Assy(2C004-00073).....	26
Figure 14 – Housing Assy(2C004-00041)	27
Figure 15 - The schematic diagram of the thruster PWM control	28



List of Tables

Table 1 - Precautions.....	6
Table 2 - DWT085D3 Specification	7
Table 3 – DWT085D3 Thruster Electrical	10
Table 4 - PWM Signal Control	10
Table 5 - Pin Assignment	10
Table 6 - Spares list.....	24
Table 7 - Tools list.....	24
Table 8 - PWM specifications.....	28



1 Introduction







1.1 General

DWTEK releases new range of brushless DC thrusters with the outstanding characters of low-weight, powerful thrust and integral electronic components. The engineering capabilities of DWTEK in subsea application drive our passion to innovate high reliable design and components to our thrusters.

DWT085D3 thruster is a heavy-duty electric underwater thruster. The design is in purpose of high efficiency and low noise stealth; meanwhile it is suitable the propulsion system of any underwater robots or high-end surface utility vehicles.

1.2 Precautions

Table 1 - Precautions

	<p>The “DANGER” symbol indicates a hazardous situation which, if not avoided, will result in death or serious injury. Carefully read the message that follows to prevent serious injury or death.</p>
	<p>The “WARNING” symbol indicates a hazardous situation which, if not avoided, could result in death or serious injury. Carefully read the message that follows to prevent serious injury or death.</p>
	<p>The “CAUTION” symbol indicates a hazardous situation which, if not avoided, could result in minor or moderate injury, or equipment damage. Carefully read the message that follows to prevent minor or moderate injury.</p>
	<p>The “NOTICE” symbol alerts to a situation that is not related to personal injury but may cause equipment damage</p>
	<p>Do not put hands near it when machine operating.</p>
	<p>Do not wear electrically conductive jewelry, clothing, or other items while working on the electrical system.</p>
	<p>An electric shock could be fatal. Ensure power to the Thruster is OFF” before opening electrical panels.</p>

2 Specifications

2.1 Thruster

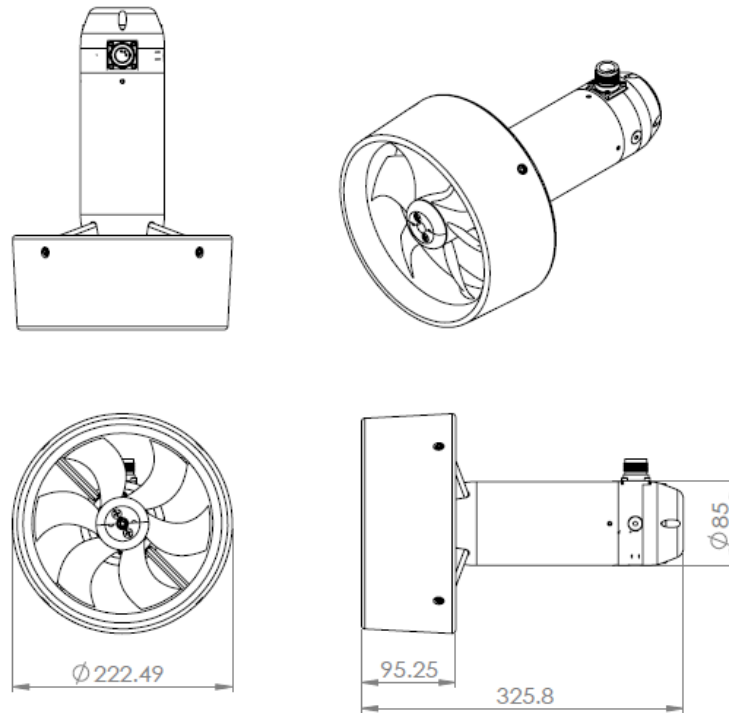
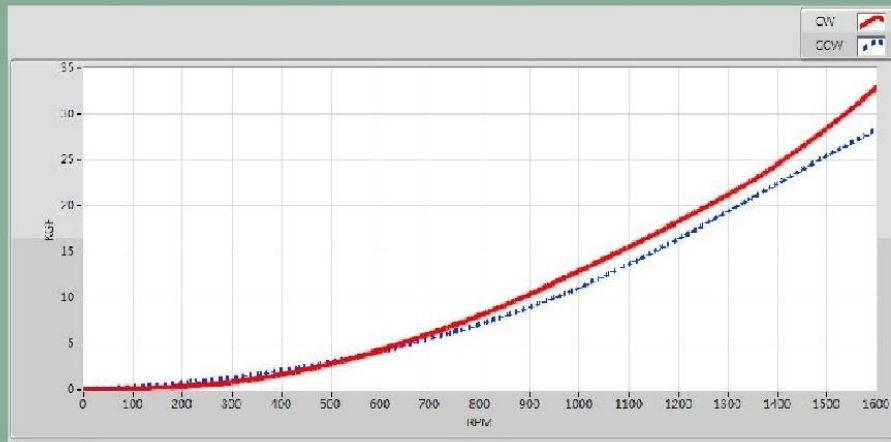

Figure 1 - DWT085D3 Thruster

Table 2 - DWT085D3 Specification

DWT085D3	
MECHANICAL	
Weight in air	5.8kg
Weight in water	3.3 kg
Standard Housing	AL 6061-T6
Propeller	Vetus 6 Blades
Nozzle	Nylon
ELECTRICAL	
Operation Voltage	300 VDC
Speed Control	0-100% PWM Signal
Drive	Direct Drive
Watt	1500W
Protection	Over-Temp / Over Current / Under Voltage / Abnormal Operation
PERFORMANCE	
Thrust	CW: 32 kgf / CCW: 27 kgf

DWT085D3-300V THRUST PERFORMANCE CURVES



RPM VS KGF

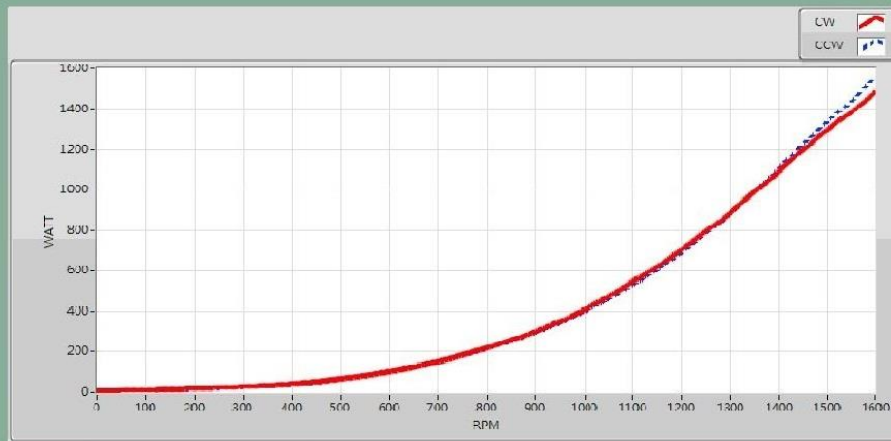

RPM VS WATT

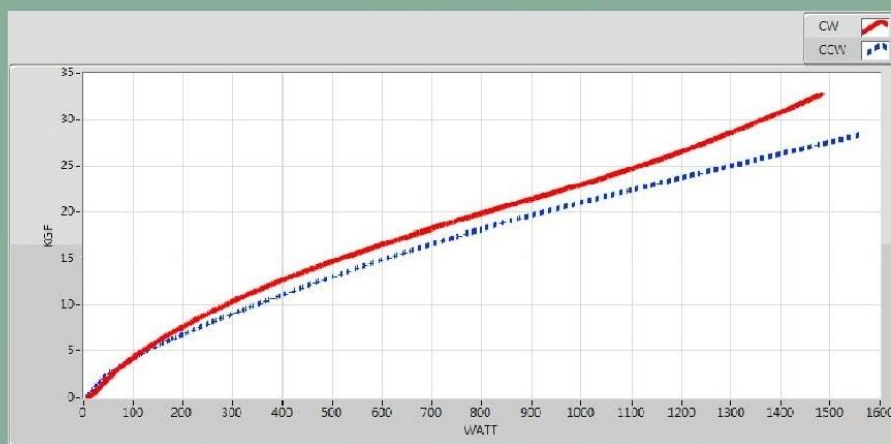

WATT VS KGF

Figure 2 - DWT085D3 Thruster performance curve



2.2 Connector

2.2.1 General

Part No.	2GM170308M-00001SS
Title	MSG8M-FCR Metal Shell G Flange Connector
Service Check	Regularly

2.2.2 Indications for Replacement

Replace if connector is damaged, deformed or no longer watertight.

2.2.3 Cleaning Procedure

General cleaning and removal of any accumulated sand or mud on a connector should be performed with spray based contact cleaner, Isopropyl Alcohol.



Warning!!

Only the qualified specialist is allowed to proceed the connector replacement.

3 Installation

3.1 Installation Guide

Table 3 – DWT085D3 Thruster Electrical

	Nominal	Max	Min
Input Voltage	300 VDC	315 VDC	285 VDC
Input Current	5 A	4.78 A	5.28 A
Instrument Power Voltage	15 V	16.5 V	13.5 V
Instrument Power Current	0.12 A	0.11 A	0.14 A

Table 4 - PWM Signal Control

	Min	Nominal	Max
PWM Voltage	4.9V	5V	5.1V
PWM Frequency	1KHz	2KHz	10KHz
PWM Adjustment	5%	48%-52%	95%

*The PWM adjustment is about $\pm 2\%$ tolerance.

Procedure of electronic Connection:

- Step1. Connect Pin3 to +300 VDC
- Step2. Connect Pin1 to HGnd
- Step3. Connect Pin5 to PWM Signal
- Step4. Connect Pin7 to PWM Signal GND
- Step5. Connect Pin4 to +15 VDC (instrument)
- Step6. Connect Pin1 to HGnd (instrument 15 VDC)

3.2 Pin Assignment

Table 5 - Pin Assignment

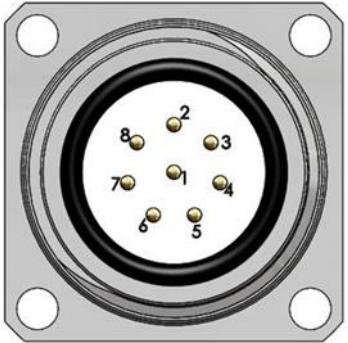
Female Inline Top View	Pin Assignment	Male Bulkhead Top View
	1 : HGnd 2 : PE 3 : +300 VDC 4 : +15 VDC 5 : PWM Signal 6 : N/A 7 : PWM Signal GND	

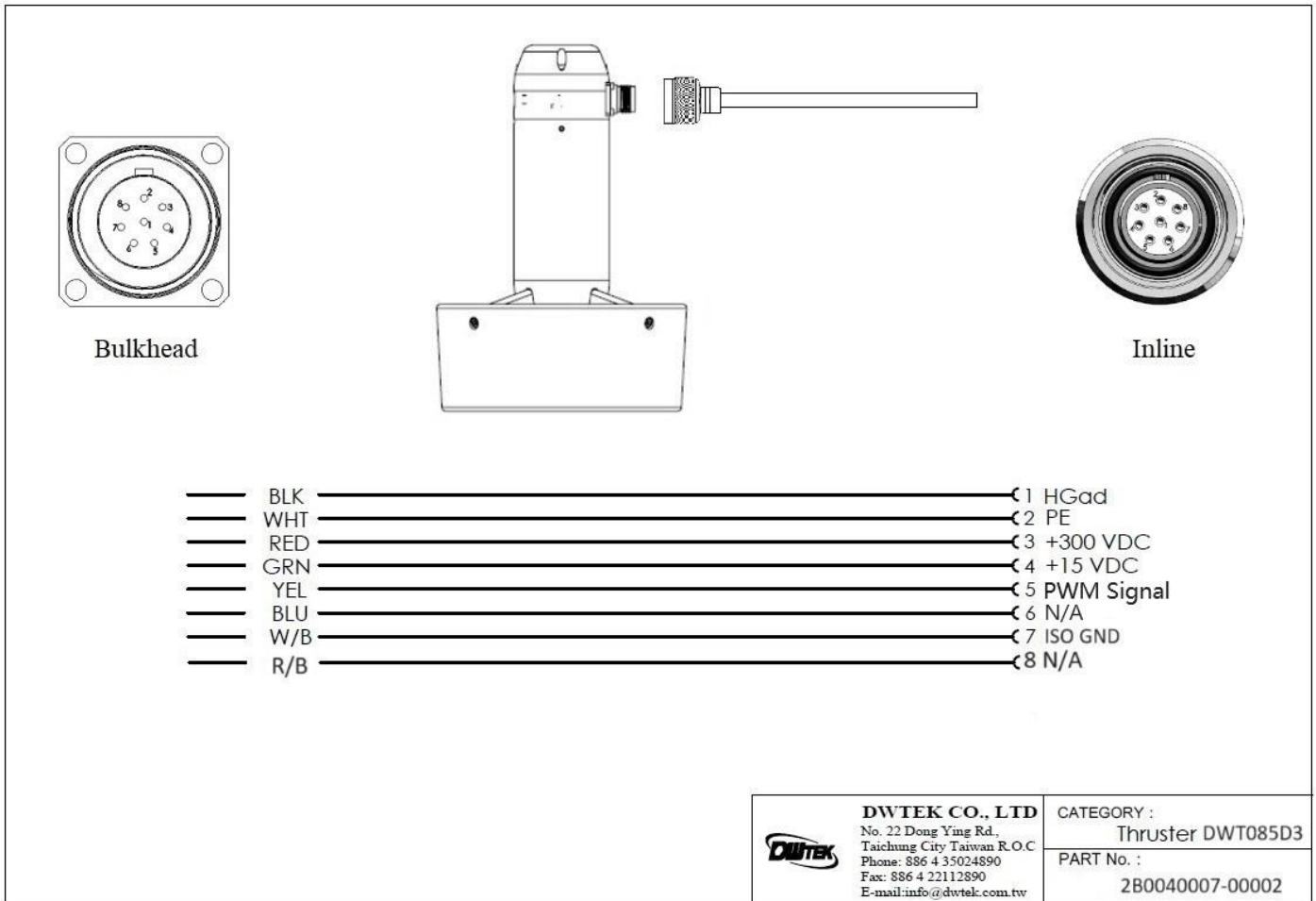

Figure 3 – DWT085D3 Thruster Pin Assignment

Make sure all the connections are correct, and follow the instruction listed as below to power the thruster.

1. Connect Pin2 to the Protection Earth point
2. Deliver +15 VDC to Pin4 and Pin1
3. Deliver PWM control signal to Pin5 and Pin7
4. Make sure PWM control signal is set within 48%-52%
5. Deliver +300 VDC to Pin3 and Pin1
6. Adjust PWM control signal to Pin5 and Pin7
7. Thruster should turn CW and CCW according to the apply PWM signal

Note!!



- 1. Control signal is set as 0 RPM within PWM 48%-52%.**
- 2. Always make sure to set the control signal within PWM 48%-52% before powering on +300Vdc to the thruster. Thruster will not be activated if control signal is out the range of PWM 48%-52% unless the control is set within PWM 48%-52%.**
- 3. The CW maximum speed is set at 95% and the CCW maximum speed is set at 5%, to avoid the maximum speed caused by 0V or 5V when the wire is broken or shorted.**
- 4. The WATT of DWT085D3 at the maximum speed is about 1500W±5%.**
- 5. After the thruster powers on, DO NOT REMOVE the PWM control signal, otherwise the speed will be abnormal.**



3.3 Maintenance and Removal

To remove the thruster, please follow below steps.

1. Disconnect the cable.
2. Install the protection dummy on the bulkhead connector.

THRUSTER FIELD & DEPOT REPAIR PROCEDURES LISTED BELOW SHALL BE CARED.



Warning!!

Make sure to switch off thruster power and auto-functions once the system is on the surface.



Caution!!

It recommends considering the replacement of the O-rings and resealing thruster as annual maintenance. DWTEK offers comprehensive annual inspection and maintenance service to guarantee reliability and performance.



Caution!!

The thruster is designed as a simple maintenance unit. After each dive, please always wash with fresh water.

4 Trouble shooting

4.1 Thruster Trouble shooting

If thruster performed:

- I. RPM unsteady.
- II. Vibration.

please proceed the initial detection procedure which mainly caused by two type of cases as below:

- I. Power output.
- II. Consumption parts and determine the replacement.

4.2 Detection Procedure

1. Make sure the propeller is free of rotation and under safety and well protection.
2. Apply +15 VDC to Pin4 and HGnd to Pin1. It recommends using power supply with the current consumption indicator. The nominal current consumption is 0.12Amp +/- 0.02.
If current consumption is out of the above range without loading, the control PCB need to be examined and replaced.
3. Measure the analog input PWM signal with multimeter and make sure PWM signal is connected to Pin5 and Pin7 PWM Signal GND.
4. Apply input voltage +300 VDC to Pin3 and HGnd to Pin1.
5. Make sure PWM signal is within 48%-52% before delivering +300 VDC to thruster.
6. Use a current indicator to wire on the power supply in series before delivering +300 VDC.
7. Make sure current output is less than 0.1A when PWM control signal is 48%-52%.



Caution!!

If the current goes higher with short circuit, the power PCB need to be examined and replaced, please do not hesitate to contact DWTEK Co., Ltd.



5 Maintenance

5.1 Nozzle

5.1.1 General

Part No.	2D004-00058
Title	Nozzle
Service Check	Replace if damaged
Tool	4mm Allen Key

The nozzle is designed to improve the performance in water. Without the nozzle, there would be a drastic thrust reduction and control failure. Thruster can be tested in air but it recommends contacting DWTEK if doing enforced dummy load in the shaft of thruster.

The nozzle consists of a cast Nylon material that is high impact-resistant.

5.1.2 Indications for Replacement

Please replace the nozzle if it damages to the point that it fouls the propeller.

5.1.3 Removal the Nozzle from Thruster`

1. Remove (4) SS Socket Head Cap Screw M5x80mm (P/N 2D004-00014) with 4mm Allen Key.
2. Remove (4) Support Rod (P/N 2D004-00051) in the Nozzle.

Installation Procedures

1. Install (4) Support Rod (P/N 2D004-00051). Make sure to align the hole in the Nozzle.
2. Put (4) SS Socket Head Cap Screw M5x80mm (P/N 2D004-00014) into Nozzle through Support Rod.
3. Secure screws with 4mm Allen Key(4.2NM).



NOTE!!

If you have any further queries, please do not hesitate to contact DWTEK Co., Ltd.

5.2 Propeller Assembly

5.2.1 General

Part No. :	2P005-SET0089
Title :	Vectus Propeller
Service Check :	Before and after each dive
Tool	1. Screw Driver 2. 4mm Allen Key

DWT085D3 thruster uses Vectus propeller that has outstanding thrust performance in operation. The thrust differences between forward and reverse thruster are within 10%.

5.2.2 Indications for Replacement

Replace it if significant wear or damage is apparent on the blades of the propeller.

5.2.3 Removal Procedures

1. Unscrew SS Socket Head Cap Screw M5x10mm (P/N 2P001-D122M5-08010) with 4mm Allen Key and washers (P/N 2P001-W422M5A and 2P001-W4NWM5A).
2. Unscrew (2) tap screws and remove (2) propeller caps.
3. Remove dowel pin and propeller from the shaft.

5.2.4 Install Procedures

1. Insert Pin 4x24mm into Shaft
2. Install Propeller onto shaft and confirm Pin touch on the Propeller groove.
3. Secure SS Socket Head Cap Screw M5x10mm (P/N 2P001-D122M5-08010) and washer (P/N 2P001-W422M5A and 2P001-W4NWM5A) to Vectus SET0089 propeller with 4mm Allen Key(4.2NM).



Warning!!

Operator is only allowed to remove propeller assembly under power off condition.



NOTE!!

If you have any further queries, please do not hesitate to contact DWTEK Co., Ltd.



6 Oil Filled and Drain

DWT085D3 Thruster needs to be oil filled in order to cool the high performance electric devices and increase the reliability of thruster for underwater operation. The inlet port is at the opposite side of the MG8M-FCR connector and outlet port is 90 degrees beside the connector. The oil-filled and drain operation may involve few skills and concepts. If anything in doubt, please feel free to contact manufacturer for instruction.

Warning!!



Morlina S2 BL or equivalent - Avoid prolonged and repeated touch with skin.

If swallowed, call a poison Control Centre or doctor immediately. Please contact the Oil manufacturer or distributor to request Safety Data Sheet and always read the Safety Data Sheet before operation.

6.1 Oil Filled

1. Put Thruster horizontally and direct the outlet port to be face up and slightly higher than thruster housing to extraction air out.

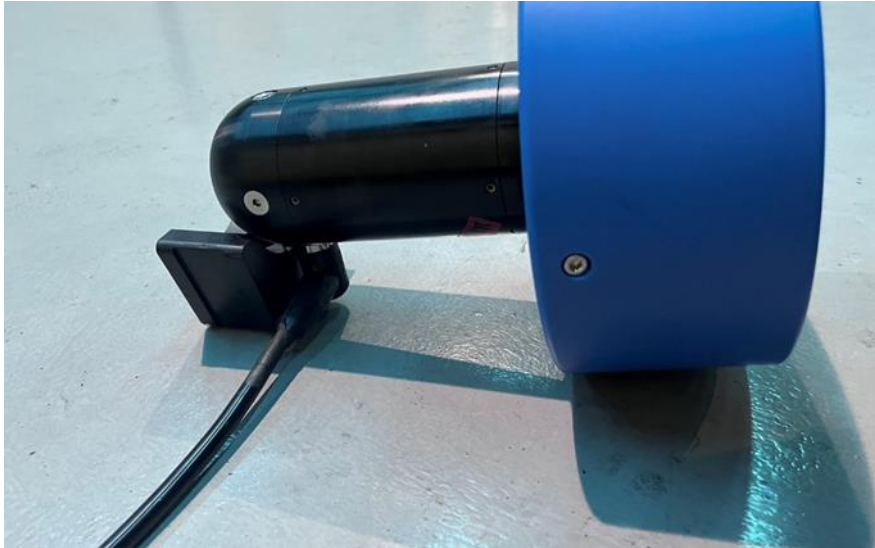

Figure 4 - Oil Filled-1

2. Release both Pressure Relief Valves (P/N 2D004-00158 ,2D003-00016).
3. Tighten the fitting valve with hose on inlet port.

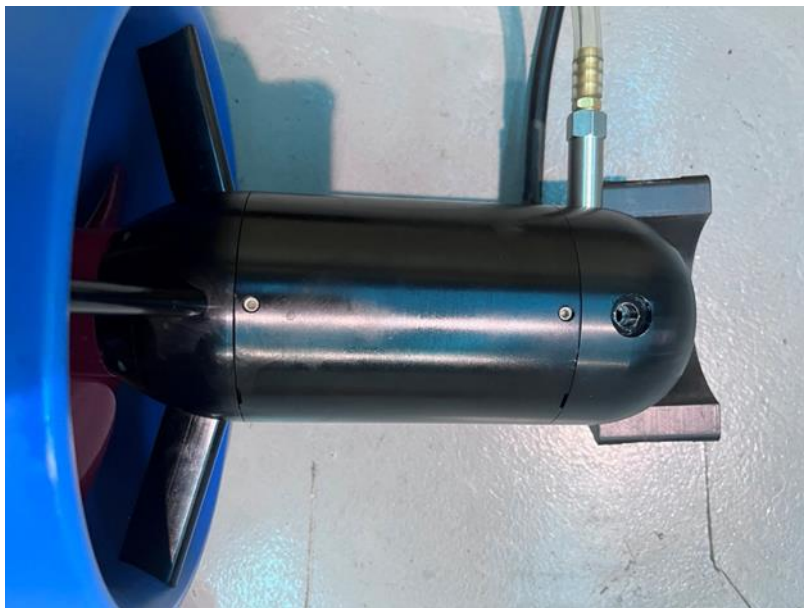

Figure 5 - Oil Filled-2

4. Fill compensation oil into a syringe then insert the plain tip into the hose
5. Inject compensation oil into thruster (around 220cc) (See Tip 1)

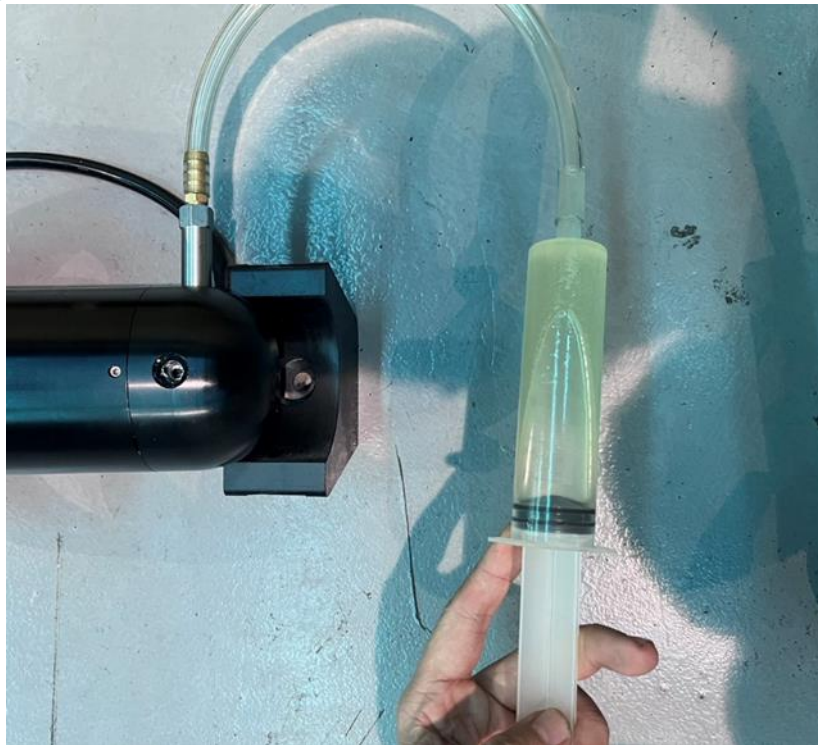

Figure 6 - Oil Filled-3

6. When oil comes out from the outlet valve, lift and down thruster nozzle few times to help air escape out of thruster.



Figure 7 - Oil Filled-4

7. Tighten the Pressure Relief Valve (P/N 2D004-00158) on outlet port then turns inlet port to face up.
8. Press plunger to pump and enforce compensation oil into thruster housing until the diaphragm bulged.



Figure 8 - Oil Filled-5

9. Retrieve plunger to suck compensation oil and lift and down thruster housing few times to help air escape out of thruster. Repeat this process several time in order to exhaust air from the thruster.



Figure 9 - Oil Filled-6



10. Remove the syringe and unscrew the fitting valve.
11. Secure the Pressure Relief Valve (P/N 2D003-00016) on inlet port.
12. Clean the table, bracket and thruster.
13. Visible leaking inspection.



Warning!!

Operator is required to wear the protection gloves and glass before start the oil fill operation.



Caution!!

Operator may use vacuum pump to test the sealing condition. Please refer to Appendix.



6.2 Drain Procedure

1. Upside down the Thruster to drain the polluted compensation oil.



Figure 10 - Drain Procedure-1

2. Release both Pressure Relief Valves (P/N 2D004-00158 ,2D003-00016) and drain the compensation oil.

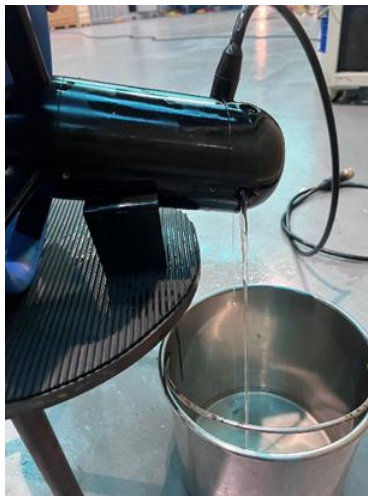

Figure 11 - Drain Procedure-2

3. Secure both Pressure Relief Valve (P/N 2D004-00158 ,2D003-00016) if no longer oil drained.



Caution!!

Visible inspection to electric driver and make sure no burned mark, loose/disconnected wire or damage. If any, please contact manufacturer.

Caution!!

Dispose polluted oil according to local regulation and protect the environment responsibly.

7 Appendix

7.1 Vacuum and Pressure Relief

All electronic components could generate heat and prohibit system operation with a vacuum condition. Pressure relief port can be used as a vacuum port for testing purpose.

Recommended vacuum test on the pod is -80kPa for a period of 30 to 60 minutes after disassemble and re-assembly. It should be released once the testing is complete. Filling in Nitrogen gas from the Nitrogen bottle with an adaptor would take out the moisture to prevent concentration.

Warning!!



- 1. Make sure that this process was carried out in a well-organized place.**
- 2. Check and clean the O-rings on pressure relief valve before installation. If they are damaged, please replace it with new one, and greased with Silicone Grease.**



7.2 Spares and Tools

Table 6 - Spares list

Item No.	Part No.	Description	Qty
1	2P001-D4N0M5-0806	M5xP0.8x6 Socket Grub Screw	4pcs
2	2D013-00014	SUS316 M5xP0.8x75 Socket Head CAP Screw	4pcs
3	2D004-00158	5/16"xT24 Pressure relief valve	1pcs
4	2D003-00016	5/16"xT24 Pressure relief valve	1pcs
5	2P002-SOR-AS142N70	ID59.99 x W2.62 O-Ring	1pcs
6	2P002-SOR-AS149N70	ID71.12 x W2.62 O-Ring	2pcs
7	2P002-SOR-AS012N70	ID9.25 x W1.78 O-Ring	2pcs
8	2D013-00013	SUS304 M5xP0.8 Self-Tapping Inserts - Slotted	4pcs
9	2P007-7203ZZKOYO	Ball Bearing	1pcs

Table 7 - Tools list

Item No.	Part No.	Description	Qty
1	2P001-FLU5M4	M4 Allen Key	1pcs

7.3 Exploded View

ITEM No.	PART No.	TITLE	DESCRIPTION	數量
1	2C004-00073	End Cap Assy	W/MC8M-FCR	1
2	2P001-D4N0M5-0804	Socket Grub Screw	M5xP0.8x4	4
3	2C004-00041	Housing ASSY	W / KBMS-14H03-C00	1
4	2D004-00051	Support Rod	w / K1401	4
5	2D004-00049	Gear Shaft Rotary Bush		1
6	2D004-00130	Constant Section Rings	ID13.5xWI.4x0.45	1
7	2C004-00043	Gear Motor Seal Cap Assy		1
8	2P001-W4NWM5A	Washer	PE 5.2x10x1	5
9	2P001-D1B2M5-08020	Socket Head CAP Screw	SUS316 M5xP0.8x20	4
10	2D004-00058	Nozzle		1
11	2D013-00014	Socket Head CAP Screw	SUS316 M5xP0.8x80	4
12	2P005-SET0089	Vetus Propeller	BOW45/50/80 Propeller	1
13	2P001-W422M5A	Washer	SUS304 5.2x10x1	1
14	2P001-D1B2M5-08015	Socket Head CAP Screw	SUS316 M5xP0.8x15	1

Pictorial View

DWTEK CO., LTD
 No. 22 Dong Ying Rd.
 Taichung City, Taiwan R.O.C
 Phone: 886 4 35024890
 Fax: 886 4 22112890
 E-mail: info@dwitek.com.tw

CATEGORY : Thruster DWT085D3
 PART No. 2B0040007-00002

Figure 12 - DWT085D3 Thruster (2B0040007-00002)

ITEM No.	PART No.	TITLE	DESCRIPTION	QTY.
1	2D004-00162	Connector Lid	DWT085D3 Thruster Lid	1
2	2P002-SOR-AS149N70	O-Ring	ID71.12 x W2.62	2
3	2P007-6001ZZNACHI	Ball Bearing	NACHI OD28 x ID12 x 8	1
4	2P001-AR5528	Circclip	R28	1
5	2P001-W4NWM4A	Washer	Ø4xØ8x1	4
6	2P001-D1B2M4-07010	Socket Head CAP Screw	SUS316 M4xP0.7x10	4
7	2D003-00016	Pressure relief valve	5/16"xT24	1
8	2P002-SOR-AS012N70	O-Ring	ID9.25 x W1.78	2
9	2D004-00060	End Cap	DWT7600 Thruster Lid	1
10	2GM170308M-00001SS	Metal Shell G Flange Connector	MSG8M-FCR	1
11	D1B2M3-0508	Socket Head CAP Screw	SUS316 M3xP0.5x8	4
12	2P002-SOR-AS142N70	O-Ring	ID59.99 x W2.62	1
13	2C004-00098	1500W Driver	1500W Driver	1
14	2D004-00158	Pressure relief valve	5/16"xT24	1

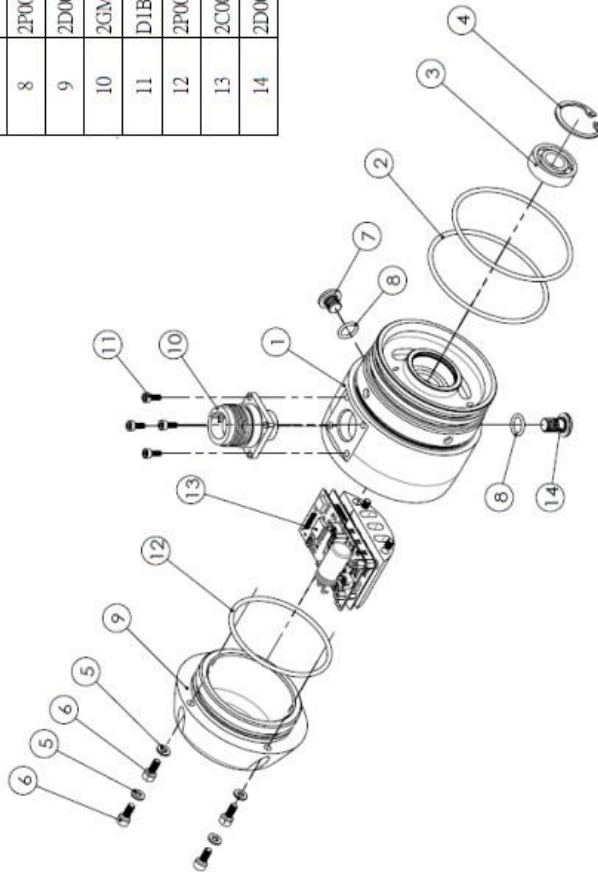

立體視圖

DWIEK CO., LTD
 No. 22 Dong Ying Rd.,
 Taichung City, Taiwan R.O.C
 Phone: 886 4 35024890
 Fax: 886 4 22112890
 E-mail: info@dwitek.com.tw



CATEGORY : End Cap Assy
 PART No. 2C004-00073

Figure 13 – End Cap Assy(2C004-00073)

ITEM No.	PART No.	TITLE	DESCRIPTION	數量
1	2P004-KBMS-14X03-C00-B	DD Motor Stator	Kollmorgen KBMS-14X03-C00	1
2	2C004-00044	Motor Rotor Assy	w / Kollmorgen KBMS-14X03-C00	1
3	2D004-00067	Housing		1
4	2D013-00013	Self-Tapping Inserts - Slotted	SUS304 M5xP0.8	4
5	2P007-7203ZZKOYO	Ball Bearing	KOYO OD40xID17x12	1

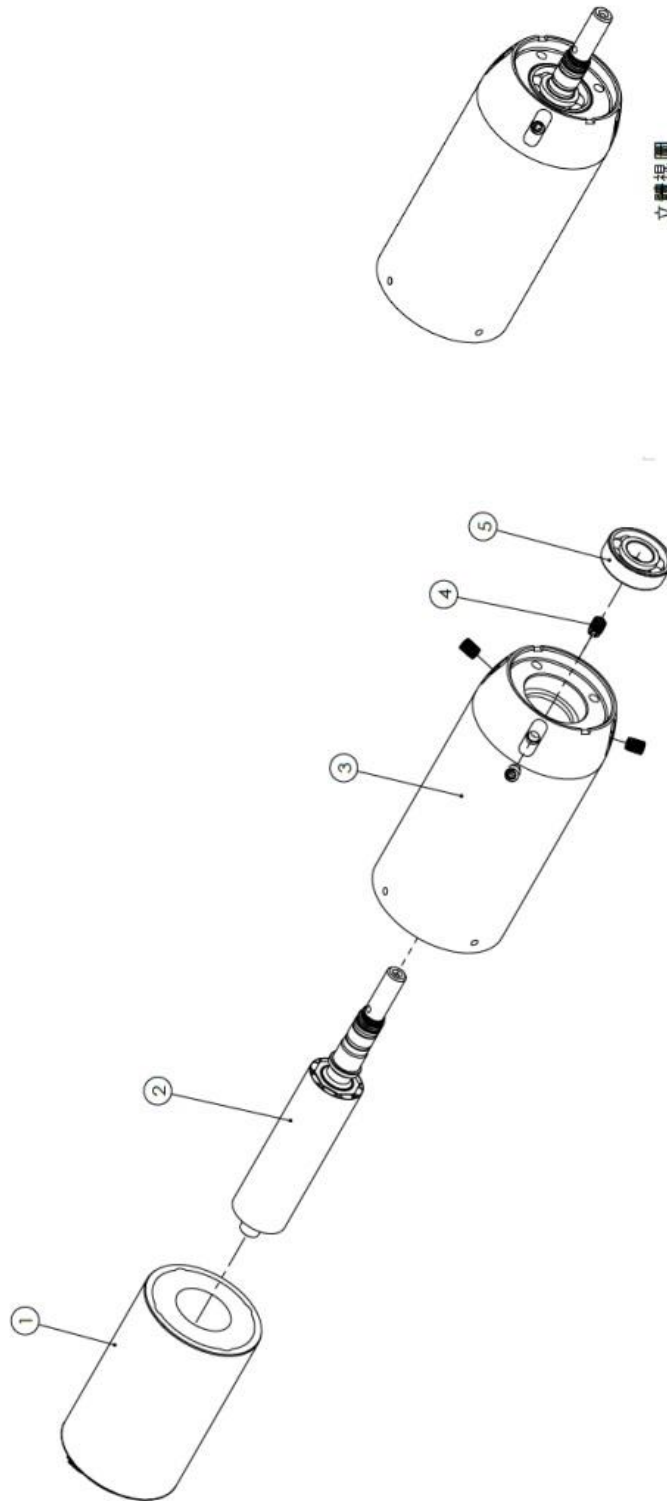

	DWTEK CO., LTD No. 22 Dong Ying Rd. Taichung City Taiwan R.O.C Phone: 886 4 35024890 Fax: 886 4 22112890 E-mail: info@dwitek.com.tw	CATEGORY : Housing Assy
	PART No. 2C004-00041	

Figure 14 – Housing Assy(2C004-00041)

7.4 PWM Signal Control

Table 8 - PWM specifications

	Min	Nominal	Max
Voltage	4.9V	5V	5.1V
Frequency	1KHz	2KHz	10KHz
Adjustment	5%	48%-52%	95%

*The PWM adjustment is about $\pm 2\%$ tolerance.

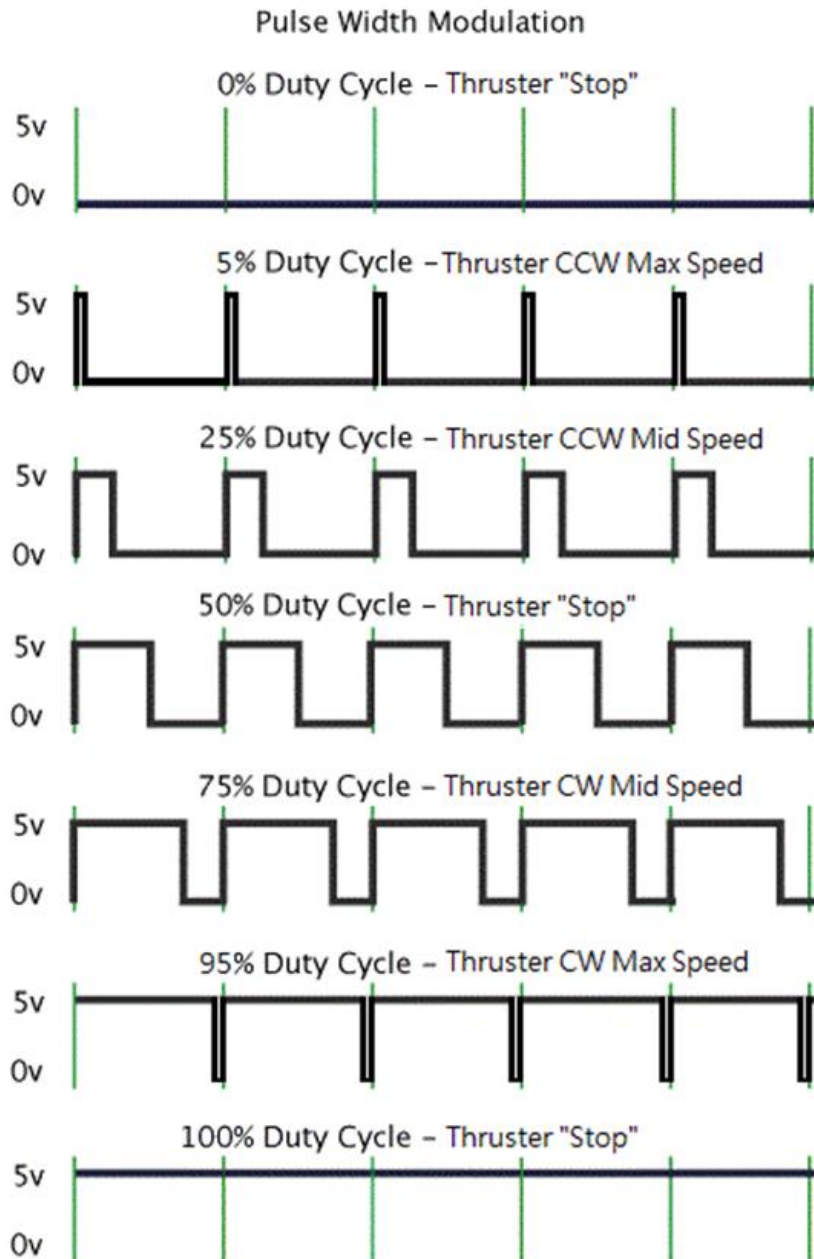

Figure 15 - The schematic diagram of the thruster PWM control

1. Thrusters are Clockwise from 53%-95%.
 - 53% are min speed Clockwise (CW)
 - 95% are max speed Clockwise (CW)
 2. Thruster is stopped at 48%-52%, 0%-5%, 95%-100%.
 3. Thrusters are Counter-Clockwise from 5%-47%.
 - 47% are min speed Counter-Clockwise (CCW)
 - 5% are max speed Counter-Clockwise (CCW)
- *The PWM adjustment is about $\pm 2\%$ tolerance.

Note!!



1. **Control signal is set as 0 RPM within PWM 48%-52%.**
2. **Always make sure to set the control signal within PWM 48%-52% before powering on +300Vdc to the thruster. Thruster will not be activated if control signal is out the range of PWM 48%-52% unless the control is set within PWM 48%-52%.**
3. **The CW maximum speed is set at 95% and the CCW maximum speed is set at 5%, to avoid the maximum speed caused by 0V or 5V when the wire is broken or shorted.**
4. **The WATT of DWT085D3 at the maximum speed is about 1500W $\pm 5\%$.**
5. **After the thruster powers on, DO NOT REMOVE the PWM control signal, otherwise the speed will be abnormal.**



The information contained in this document is subject to be modified and/or supplemented from time to time by DWTEK Co., Ltd without prior notice.

DWTEK Co., Ltd shall not be liable for any loss, errors or damage in connection with information in this document.

Copyright © 2023 DWTEK Co., Ltd. All rights reserved.