



Operator's Manual

Sea Bright LED - 50W

DWTEK Co., Ltd

No.22, Dong Ying Rd., East District, Taichung City 401, TAIWAN

T: +886-4-3502-4890 | E: info@dwtek.com.tw

F: +886-4-2211-2890 | W: www.dwtekmarine.com

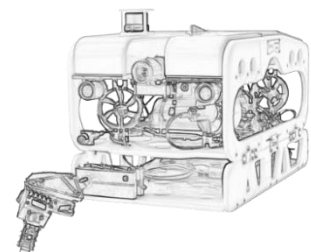



Table Of Contents

1 Introduction

1.1 General	3
1.2 Precautions	4

2 Specifications

2.1 Sea Bright LED	5
2.2 Connector	9
2.3 General	11
2.4 Indications for Replacement	11
2.5 Installation Procedures	11

3 Installation

3.1 Installation Guide	12
3.2 Pin Assignment	12
3.3 Maintenance and Removal	14

4 Trouble shooting

4.1 Thruster Trouble Shooting.	15
4.2 Detection Procedure.	15

5 Maintenance

5.1 Acrylic.	16
----------------------	----

6 Appendix

6.1 Vacuum and Pressure Relief.	17
---	----



1 Introduction







1.1 General

The lamp housing is constructed from hard anodized Aluminum-6061 T6 and is designed to operate at depth of 6000M. The front port is manufactured from optical quality high strength Acrylic.

The 50W LED is designed for in-water operation. Running the lamp in air for long period of time is not recommended and will reduce lamp lifetime. If the internal temperature exceeds 60°C, thermal protection would automatically activate and the output power will reduce below 10% of normal output until the internal temperature returns to 60°C.

When the 50W LED lamp is operated in the air, the housing may reach temperature of 60°C that may cause burns if the housing is handled without protective glove.

1.2 Precautions

	<p>The “DANGER” symbol indicates a hazardous situation which, if not avoided, will result in death or serious injury. Carefully read the message that follows to prevent serious injury or death.</p>
	<p>The “WARNING” symbol indicates a hazardous situation which, if not avoided, could result in death or serious injury. Carefully read the message that follows to prevent serious injury or death.</p>
	<p>The “CAUTION” symbol indicates a hazardous situation which, if not avoided, could result in minor or moderate injury, or equipment damage. Carefully read the message that follows to prevent minor or moderate injury.</p>
	<p>The “NOTICE” symbol alerts to a situation that is not related to personal injury but may cause equipment damage</p>
	<p>Do not put hands near it when machine operating.</p>
	<p>Do not wear electrically conductive jewelry, clothing, or other items while working on the electrical system.</p>
	<p>An electric shock could be fatal. Ensure power to the Thruster is OFF” before opening electrical panels.</p>



2 Specifications

2.1 Sea Bright Searchlight (50W LED)

2.1.1 Standard

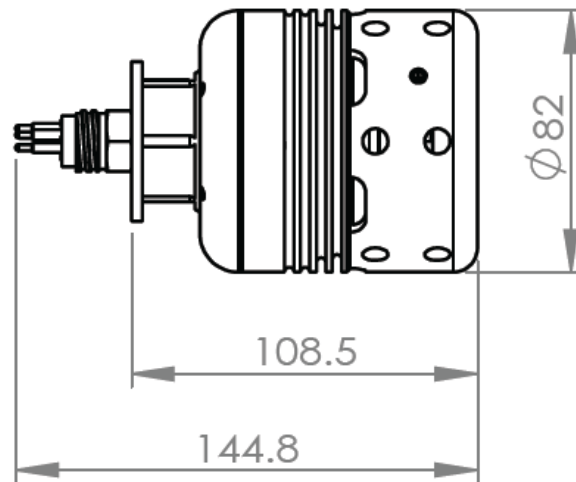

DWTEK-50W	
Input	24~52 VDC ; 50W
Lumens in Integrating Sphere	> 2500 Lumens @ 50W
Luminous Efficacy	50 lm/W
Current Draw	1.06 A @ 48 VDC
Dimming	0-5V analog / 0-100% PWM (Isolation Inside for Opt.)
Color Temp.	6,000~6,500°K
Beam Pattern	72°
Body Material	Hard Anodized 6061-T6 Aluminum
Window Material	Acrylic
Depth Rating	6,000 m
Testing Rating	600 Bar
Operation Temp.	-10°C ~ 40°C
LED Lifespan	50,000 hrs
Weight	820 g (in Air) ; 400 g (in Water)
Connector	MCBH 5M / Pigtail(Optional)



補爆炸圖

2.2 Connector

2.2.1 Micro Circular

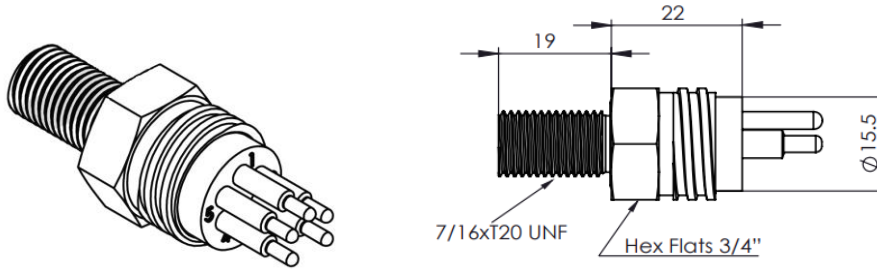

2GW100605M-00001 (MCBH05MBR)	
Operation Specification	
Max. voltage	300 VDC
Current rating @contact	Contact 2,3,4: 10A
	Contact 5,6,8: 5A
	Contact 10,12,16: 5A
Max. current @connector	Contact 2,3,4,5,6,8: 20A
	Contact 10,12,16: 30A
Insulation resistance	> 200 Mohm
Contact resistance	< 0.01 ohm
Wet matings	> 500 times
Depth rating	600 bar (300 bar for peek)
Temperature rating	- 40 to 60°C
Material Specification	
Connector body	Chloroprene rubber
Bulkhead body	Brass (BR), stainless steel 316 (SS), anodized aluminum (AL), titanium (TI)
Contact	Gold plated brass
Socket	Beryllium copper
Location pin	Stainless steel 316
Bulkhead leads	Contact 2,3,4: AWG 18 PTFE, 30cm (AWG 20 PTFE optional)
	Contact 5,6,8: AWG 20 PTFE, 30cm (AWG 22 PTFE optional)
	Contact 10,12,16: AWG 20 PTFE, 30cm
O - rings	NBR 2-014

2.3 General

Part No.	2GW100605M-00001
Title	Micro Circular Bulkhead
Service Check	Regularly
Tool	None

50W LED function with MCBH5MBR connector.

2.4 Indications for Replacement

Replace if connector is damaged, deformed or no longer watertight.

2.5 Installation Procedures

For greasing and mating above water (dry mate)

1. Connectors must be greased with Molykote 44 Medium before each mating.
2. A layer of grease corresponding to minimum 1/10 of socket depth should be applied to the female connector.
3. The inner edge of all sockets should be completely covered, and a thin transparent layer of grease should be left visible on the face of the connector.
4. After greasing, fully mate the male and female connector in order to secure optimal distribution of grease on pins and in sockets.
5. To confirm that grease has been sufficiently applied, de-mate and check for grease on each male pin, then re-mate the connector.

For Cleaning

1. General cleaning and removal of any accumulated sand or mud on a connector should be performed with spray based contact cleaner, Isopropyl Alcohol.
2. New grease must be applied again before mating.

Caution!!



It always recommends applying dummy plug for watertight protection when storage and operation.

Warning!!



Only the qualified specialist is allowed to proceed the connector replacement.

3 Installation

3.1 Installation Guide

LED Electrical and Control Signal

	Nominal	Max	Min
Input Voltage	48 VDC	52 VDC	24 VDC
Input Current	1.06A	0.98A	2.1A
No Dimming	-	-	-
Dimming 0-5V	-	5V	0V
Dimming PWM (Option)	50%	100%	0%

Procedure of electronic Connection:

1. Cable Black /Pin1 to GND
2. Cable White /Pin2 to Chassis
3. Cable Red /Pin3 to +48 VDC
4. Cable Green /Pin4 to Dimming +
5. Cable Orang /Pin5 to Dimming -

3.2 Pin/Cable Assignment

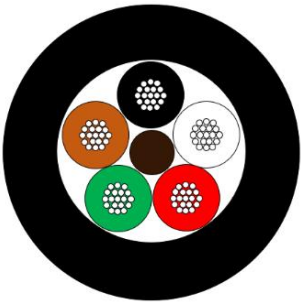
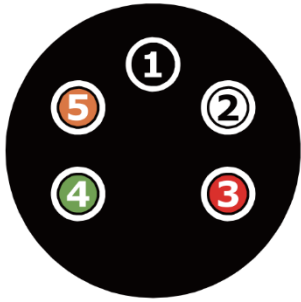
Cable Top View	Num of Pin	Cable Code	Assignment	Bulkhead Top View (Male)
	1	Black	GND	
	2	White	Chassis	
	3	Red	VCC	
	4	Green	Dimming +	
	5	Orang	Dimming -	

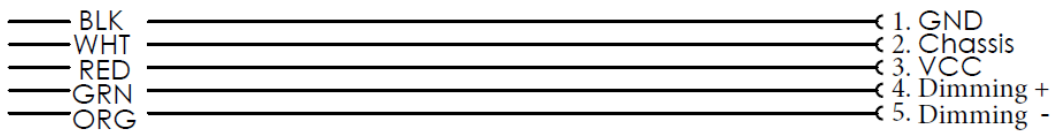
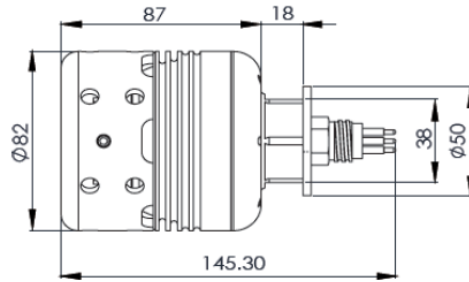

 DWTEK CO., LTD No. 22 Dong Ying Rd., Taichung City Taiwan R.O.C Phone: 886 4 35024890 Fax: 886 4 22112890 E-mail: info@dwtek.com.tw	CATEGORY :
	50W- LED
	PART No. :
	2B0030003-00001

V1.0

Make sure all the connection is correct, and then follow the instruction listed as below to power the 80W LED.

1. Deliver GND to BLACK
2. Deliver +48 VDC to RED
3. Deliver Chassis to WHITE
4. Adjust PWM control signal to GREEN and ORANG



3.3 Maintenance and Removal

1. The lamp has been designed from the outset with a view towards simple straight forward operation and maintenance. All the lamp main parts are replaceable with instruction. Please contact DWTEK for details. If the connector requires for replacement, it is suggested that a thread lock compound be used to hold the connector firm.
2. If any parts of the lamp are removed for maintenance, the O-ring seals should have damage check and be lightly greased and cleaned before the lamp is reassembled.
3. Care should be taken not to scratch the front window when cleaning it with soft cloth and soapy water.

To remove the LED, please follow below steps.

1. Disconnect the cable.
2. Install the protection dummy on the bulkhead connector

LED FIELD & DEPOT REPAIR PROCEDURES LISTED BELOW SHALL BE CARED.



Warning!!

Make sure to switch off LED power the system is on the surface.



Caution!!

The LED is designed as a simple maintenance unit. After each dive, please always wash with fresh water.



4 Trouble shooting

4.1 LED Trouble shooting

If 50W LED performed:

I. No light up.

please proceed the initial detection procedure which mainly caused by one type of case as below:

I. Power output.

4.2 Detection Procedure

1. Use a multimeter to confirm that the voltage has a normal output, and the cable BLACK is connected to GND, and RED is connected to VCC.
2. Make sure that the LED is unobserved and in safe and well-protected condition.
3. It is recommended to use a power supply with a current consumption display to check the power consumption. If there is no power consumption, please contact the original factory and send it back for testing.



Caution!!

If the current goes higher with short circuit, the PCB need to be examined and replaced.



5 Maintenance

5.1 Acrylic

5.1.1 General

Part No.	2D003-00011
Title	Acrylic window
Service Check	Dirty
Tool	Alcohol 、 Clean Paper

1. When cleaning the acrylic, use a soft cloth dampened with water to wipe it. Do not use pickle cloth or coarse cloth to avoid scratching the acrylic. Acrylic can be cleaned with rubbing alcohol and cleaning paper.
2. It is recommended to spray it on a soft cloth before wiping.
3. Do not use high-concentration alcohol to avoid fogging or cracking of the acrylic

6 Appendix

6.1 Vacuum and Pressure Relief

All electronic components could generate heat and prohibit system operation with a vacuum. Pressure relief port can be used as a vacuum port for testing purpose.

Recommended vacuum test on the pod is -80kPa for a period of 30 to 60 minutes after disassemble and re-assembly. It should be released once the testing is complete. Filling in Nitrogen gas from the Nitrogen bottle with an adaptor would take out the moisture to prevent concentration

Warning!!



- 1. Make sure that this process was carried out in a well-organized place.**
- 2. Check and clean the O-rings on pressure relief valve before installation. If they are damaged, please replace it with new one.**
- 3. Improper installation or skipping installation in secure fasteners and pressure relief valve after re-assembly could bring catastrophic system failure.**