



Operator's Manual

DWT 1-48V Thruster

2T01-00003 24/04

DWTEK Co., Ltd

No.22, Dong Ying Rd., East District, Taichung City 401, TAIWAN

T: +886-4-3502-4890 | E: info@dwtek.com.tw

F: +886-4-2211-2890 | W: www.dwtekmarine.com

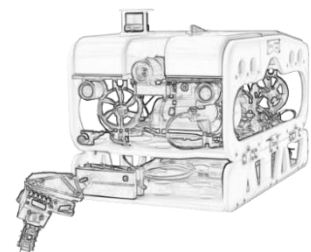



Revision information

Issue	Revisions	Date	Revised	Approver
1	First edition	2024/1/25	LIAO YU TSO	Mike Chen
2	Remove Thruster RS-485 Communication Protocol Watch dog	2024/4/30	LIAO YU TSO	Jerome Huang



Table of Contents

1	Introduction	6
1.1	General.....	6
1.2	Precautions	7
2	Specifications.....	8
2.1	Thruster	8
2.2	Connector.....	10
2.2.1	General.....	10
2.2.2	Indications for Replacement	10
2.2.3	Installation Procedures.....	10
3	Installation.....	11
3.1	Installation Guide.....	11
3.2	Pin Assignment	11
3.3	Maintenance and Removal.....	13
4	Trouble shooting	14
4.1	Thruster Trouble shooting	14
4.2	Detection Procedure.....	14
5	Maintenance	15
5.1	Nozzle	15
5.1.1	General.....	15
5.1.2	Indications for Replacement	15
5.1.3	Removal the Nozzle from Thruster	15
5.1.4	Installation Procedures.....	15
5.2	Propeller Assembly	16
5.2.1	General.....	16
5.2.2	Indications for Replacement	16
5.2.3	Removal Procedures	16
5.2.4	Install Procedures	16
5.3	Gear Shaft Seal Assy.....	17
5.3.1	General.....	17
6	Appendix.....	18
6.1	Vacuum and Pressure Relief	18
6.2	Spares and Tools.....	19
6.3	Exploded View.....	20
6.4	RS485 Signal Control	26



List of Figures

Figure 1 - DWT 1 Thruster	8
Figure 2 - DWT 1 Thruster performance curve	9
Figure 3 - DWT 1 Thruster Pin Assignment	12
Figure 4 - DWT 1 Thruster Spares.....	19
Figure 5 - DWT 1 Thruster (2B0040003-00003).....	20
Figure 6 – Housing + End Cap Assy (2C004-00134).....	21
Figure 7 – Housing + Magnet Hull Assy (2C004-00133)	22
Figure 8 - End Cap Assy (2C004-00107)	23
Figure 9 - Reducer + Magnet Hull Assy (2C004-00105)	24
Figure 10 - Magnet Hull Assy (2C004-00103).....	25
Figure 11 - Thruster RS-485 Communication Protocol.....	26
Figure 12 - Setting for CW/CCW Speed & ID	26
Figure 13 - Query for Speed & ID	27
Figure 14 - Response for Speed & ID.....	27



List of Tables

Table 1 - Precautions.....	7
Table 2 - DWT 1 Specification	8
Table 3 - DWT 1 Thruster Electrical.....	11
Table 4 - Pin Assignment	11
Table 5 - Spares list.....	19
Table 6 - Tools list.....	19



1 Introduction







1.1 General

DWTEK releases new range of brushless DC thrusters with the outstanding characters of low-weight, powerful thrust and integral electronic components. The engineering capabilities of DWTEK in subsea application drive our passion to innovate high reliable design and components to our thrusters.

DWT 1 thruster is a heavy-duty electric underwater thruster. The design is in purpose of high efficiency and low noise stealth; meanwhile it is suitable the propulsion system of any underwater robots or high-end surface utility vehicles.

1.2 Precautions

Table 1 - Precautions

	<p>The “DANGER” symbol indicates a hazardous situation which, if not avoided, will result in death or serious injury. Carefully read the message that follows to prevent serious injury or death.</p>
	<p>The “WARNING” symbol indicates a hazardous situation which, if not avoided, could result in death or serious injury. Carefully read the message that follows to prevent serious injury or death.</p>
	<p>The “CAUTION” symbol indicates a hazardous situation which, if not avoided, could result in minor or moderate injury, or equipment damage. Carefully read the message that follows to prevent minor or moderate injury.</p>
	<p>The “NOTICE” symbol alerts to a situation that is not related to personal injury but may cause equipment damage</p>
	<p>Do not put hands near it when machine operating.</p>
	<p>Do not wear electrically conductive jewelry, clothing, or other items while working on the electrical system.</p>
	<p>An electric shock could be fatal. Ensure power to the Thruster is OFF” before opening electrical panels.</p>

2 Specifications

2.1 Thruster

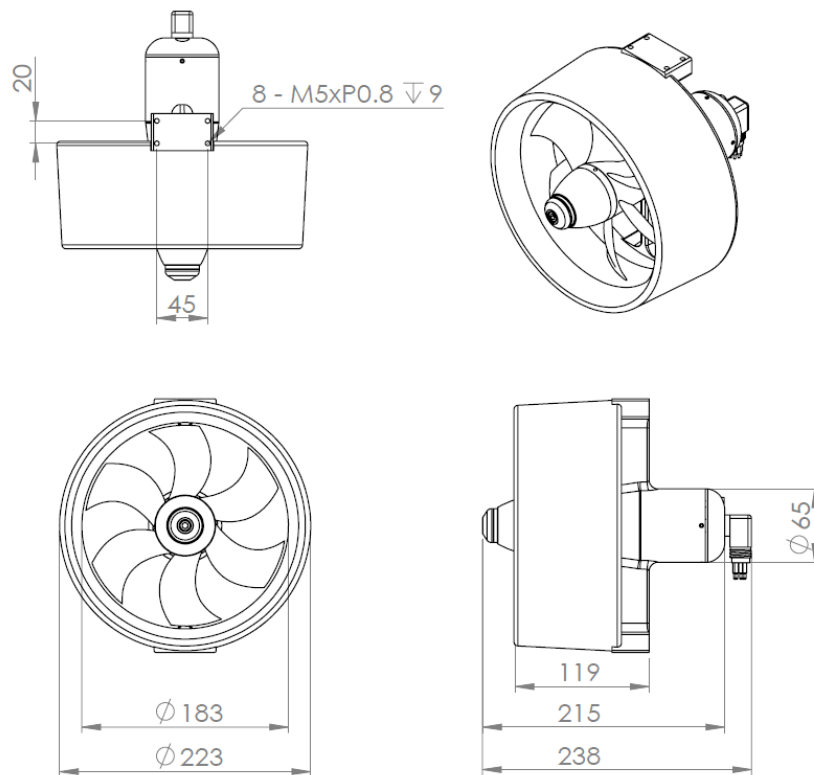

Figure 1 - DWT 1 Thruster

Table 2 - DWT 1 Specification

DWT 1	
MECHANICAL	
Weight in air	4 kg
Weight in water	1.6 kg
Standard Housing	AL 6061-T6
Propeller	Engineering Plastic Bow Propeller
Nozzle	Nylon
ELECTRICAL	
Operation Voltage	48VDC
Speed Control	RS485
Drive	Gear Reducer
Watt	500W
Protection	Over-Temp / Over Current / Under Voltage / Abnormal Operation
PERFORMANCE	
Thrust	CW: 13 kgf / CCW: 12 kgf

DWT 1

THRUST PERFORMANCE CURVES

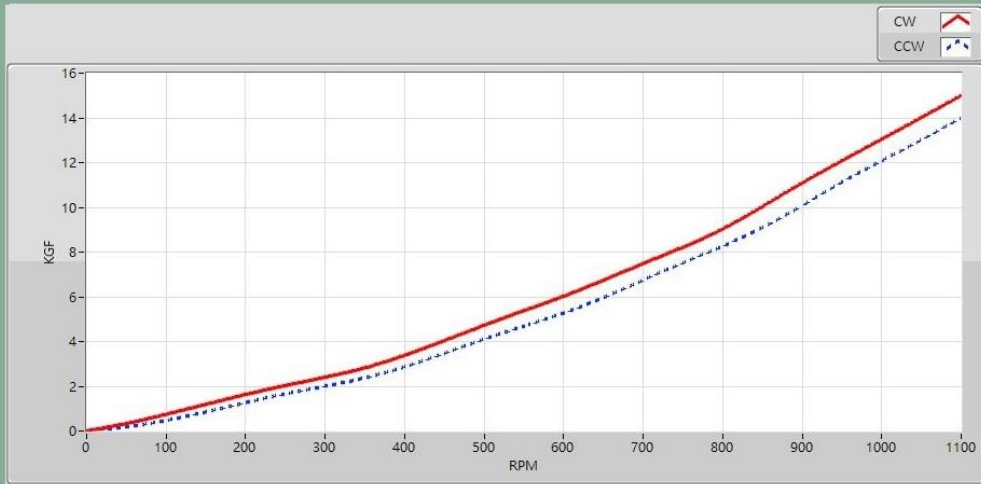

RPM VS KGF

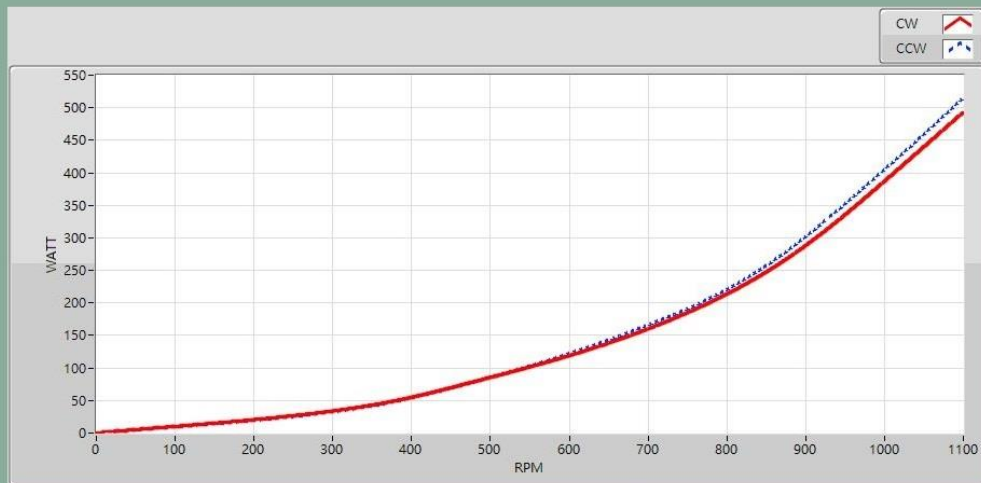

RPM VS WATT

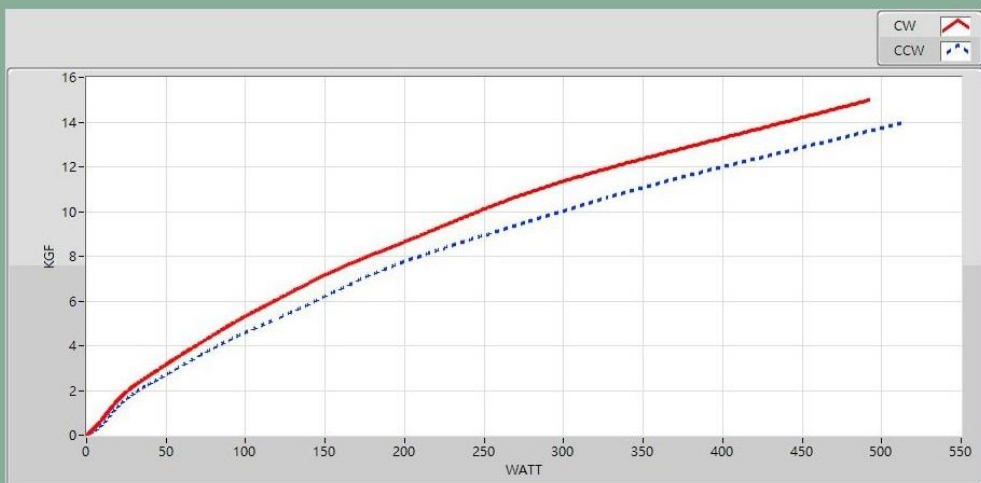

WATT VS KGF

Figure 2 - DWT 1 Thruster performance curve

2.2 Connector

2.2.1 General

Part No.	2GW100708M-00001
Title	Mini Bulkhead Right Angle Connector
Service Check	Regularly

2.2.2 Indications for Replacement

Replace if connector is damaged, deformed or no longer watertight.

2.2.3 Installation Procedures

For greasing and mating above water

1. Connectors must be greased with Molykote 44 Medium before each mating.
2. A layer of grease corresponding to minimum 1/3 of socket depth should be applied to the female connector.
3. The inner edge of all sockets should be completely covered, and a thin transparent layer of grease should be left visible on the face of the connector.
4. After greasing, fully mate the male and female connector in order to secure optimal distribution of grease on pins and in sockets.
5. To confirm that grease has been sufficiently applied, de-mate and check for grease on each male pin, then re-mate the connector.

For Cleaning

1. General cleaning and removal of any accumulated sand or mud on a connector should be performed with spray based contact cleaner, Isopropyl Alcohol.
2. New grease must be applied again before mating.



Warning!!

Only the qualified specialist is allowed to proceed the connector replacement.

3 Installation

3.1 Installation Guide

Table 3 - DWT 1 Thruster Electrical



	Nominal	Max	Min
Input Voltage	48 VDC	52 VDC	44 VDC
Input Current	10.42A	9.62A	11.36A

Procedure of electronic Connection:

- Step1. Connect Pin3 & Pin4 to +48 VDC
- Step2. Connect Pin1 & Pin2 to GND
- Step3. Connect Pin5 to RS485-A
- Step4. Connect Pin6 to RS485-B
- Step5. Connect Pin7 to ISO GND

3.2 Pin Assignment

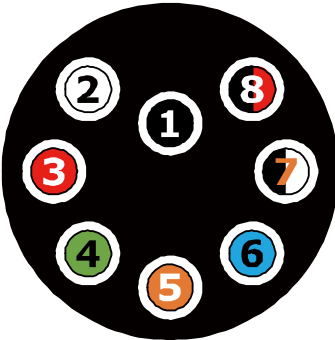
Table 4 - Pin Assignment

Female Inline Top View	Pin Assignment	Male Bulkhead Top View
	1 : GND 2 : GND 3 : +48 VDC 4 : +48 VDC 5 : RS485-A 6 : RS485-B 7 : ISO GND 8 : PE	

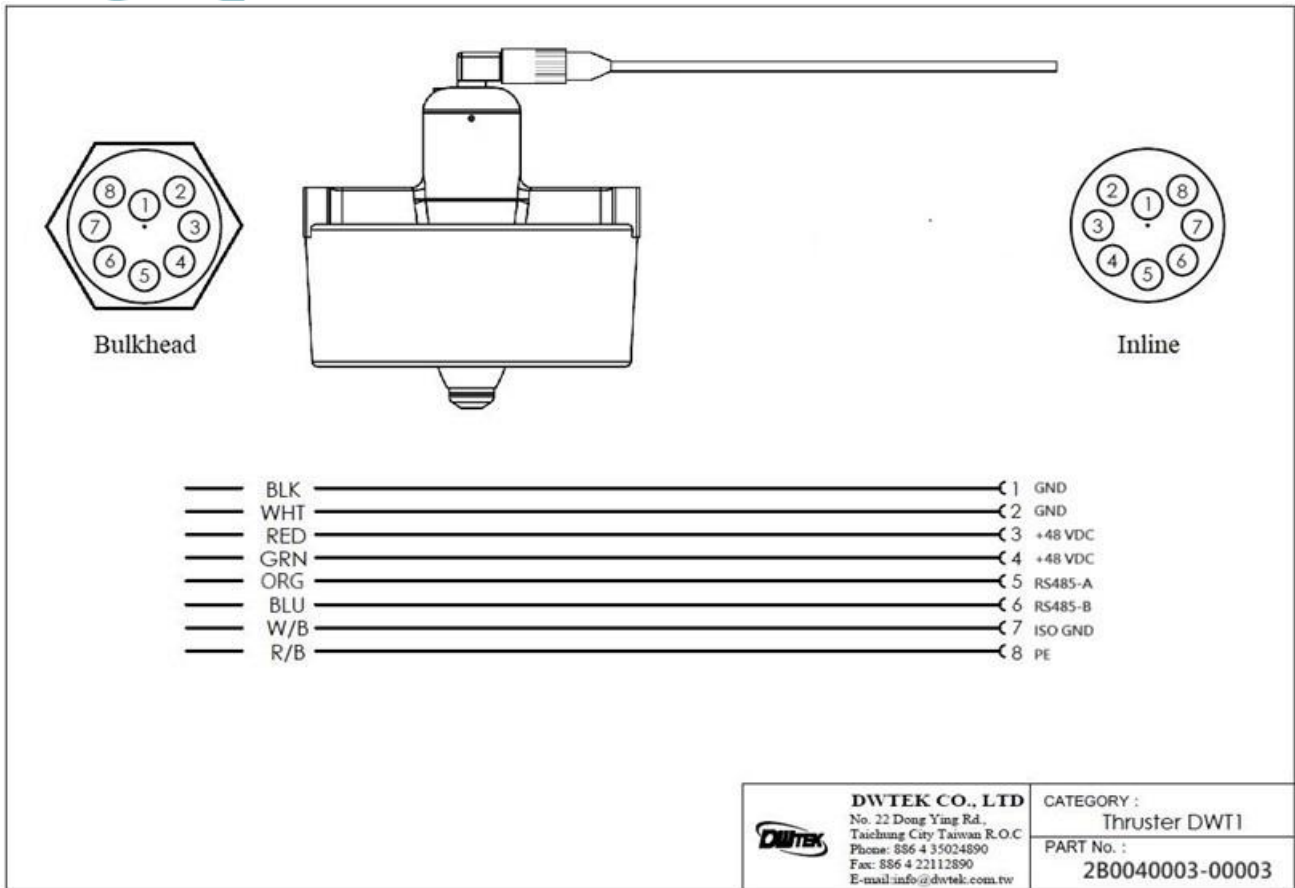

Figure 3 - DWT 1 Thruster Pin Assignment

Make sure all the connections are correct, and follow the instruction listed as below to power the thruster.

1. Connect Pin8 to the Protection Earth point
2. Deliver RS485 control signal to Pin5 and Pin6
3. Deliver +48 VDC to Pin3 、 Pin4 and GND to Pin1 、 Pin2
4. Thruster should turn CW and CCW according to the apply RS485 signal

Note!!



1. **The WATT of DWT1 at the maximum speed is about 500W±10%.**



3.3 Maintenance and Removal

To remove the thruster, please follow below steps.

1. Disconnect the cable.
2. Install the protection dummy on the bulkhead connector

THRUSTER FIELD & DEPOT REPAIR PROCEDURES LISTED BELOW SHALL BE CARED.



Warning!!

Make sure to switch off thruster power and auto-functions once the system is on the surface.



Caution!!

It recommends considering the replacement of the O-rings and resealing DWT 1 thruster as annual maintenance. DWTEK offers comprehensive annual inspection and maintenance service to guarantee reliability and performance.



Caution!!

The thruster is designed as a simple maintenance unit. After each dive, please always wash with fresh water.

4 Trouble shooting

4.1 Thruster Trouble shooting

If thruster performed:

- I. RPM unsteady.
- II. Vibration.

please proceed the initial detection procedure which mainly caused by two type of cases as below:

- I. Power output.
- II. Consumption parts and determine the replacement.

4.2 Detection Procedure

1. Make sure the propeller is free of rotation and under safety and well protection.
2. Apply input voltage +48 VDC to Pin3 、 Pin4 and GND to Pin1 、 Pin2. It recommends using power supply with the current consumption indicator. The nominal current consumption is 0.04Amp +/- 0.02.

If current consumption is out of the above range without loading, the control PCB need to be examined and replaced.

3. Deliver RS485 control signal to Pin5 and Pin6.
4. Use a current indicator to wire on the power supply in series before delivering +48 VDC.
5. Make sure current output is less than 0.1A when control signal is 0V.



Caution!!

If the current goes higher with short circuit, the power PCB need to be examined and replaced, please do not hesitate to contact DWTEK Co., Ltd.



5 Maintenance

5.1 Nozzle

5.1.1 General

Part No.	2D004-00164
Title	Nozzle
Service Check	Replace if damaged
Tool	4mm Allen Key

The nozzle is designed to improve the performance in water. Without the nozzle, there would be a drastic thrust reduction and control failure. Thruster can be tested in air but it recommends contacting DWTEK if doing enforced dummy load in the shaft of thruster.

The nozzle consists of a cast Nylon material that is high impact-resistant.

5.1.2 Indications for Replacement

Please replace the nozzle if it damages to the point that it fouls the propeller.

5.1.3 Removal the Nozzle from Thruster

Remove (4) Socket Head CAP Screw M5x30mm (P/N:2P001-D1B2M5-08030) with 4mm Allen Key.

5.1.4 Installation Procedures

- 1.Put (4) Socket Head CAP Screw M5x30mm (P/N:2P001-D1B2M5-08030) into the Nozzle screw hole.
- 2.Secure screws with 4mm Allen Key(4.2NM).



NOTE!!

If you have any further queries, please do not hesitate to contact DWTEK Co., Ltd.

5.2 Propeller Assembly

5.2.1 General

Part No. :	2C004-00104
Title :	Paddle Assy
Service Check :	Before and after each dive
Tool	5mm Allen Key

DWT 1 thruster uses Vectus propeller that has outstanding thrust performance in operation. The thrust differences between forward and reverse thruster are within 10%.

5.2.2 Indications for Replacement

Replace it if significant wear or damage is apparent on the blades of the propeller.

5.2.3 Removal Procedures

1. Unscrew Socket Head CAP Screw M6x12mm (P/N:2P001-D1B2M6-10012) with 5mm Allen Key and Spring Washer (P/N:2P001-W122M6) 、 Propellor Retainer(P/N:2D004-00122).
2. Remove Paddle Assy (P/N:2C004-00104) from the shaft.

5.2.4 Install Procedures

1. Install Paddle Assy (P/N:2C004-00104) into the shaft.
2. Secure Socket Head CAP Screw M6x12mm (P/N:2P001-D1B2M6-10012) and Spring Washer (P/N:2P001-W122M6) 、 Propellor Retainer(P/N:2D004-00122) with 5mm Allen Key(7.1NM).



Warning!!

Operator is only allowed to remove propeller assembly under power off condition.



NOTE!!

If you have any further queries, please do not hesitate to contact DWTEK Co., Ltd.



5.3 Gear Shaft Seal Assy

5.3.1 General

Part No. : 2C004-00105
Title : Reducer + Magnet Hull Assy
Service Check : Before and after each dive

Operator needs to check the sealing condition before and after each dive. If any damage or leaking are detected, please do not hesitate to contact DWTEK Co., Ltd



NOTE!!

If you have any further queries, please do not hesitate to contact DWTEK Co., Ltd

6 Appendix

6.1 Vacuum and Pressure Relief

All electronic components could generate heat and prohibit system operation with a vacuum condition. Pressure relief port can be used as a vacuum port for testing purpose.

Recommended vacuum test on the pod is -80kPa for a period of 30 to 60 minutes after disassemble and re-assembly. It should be released once the testing is complete. Filling in Nitrogen gas from the Nitrogen bottle with an adaptor would take out the moisture to prevent concentration.

Warning!!



- 1. Make sure that this process was carried out in a well-organized place.**
- 2. Check and clean the O-rings on pressure relief valve before installation. If they are damaged, please replace it with new one, and greased with Molykote 44 Medium.**

6.2 Spares and Tools

Table 5 - Spares list

Item No.	Part No.	Description	Qty
1	2P001-D1B2M6-10012	SUS316 M6xP1.0x12 Socket head cap screw	1pcs
2	2P002-SOR-AS117N70	AS-117 O-Ring	1pcs
3	2P002-SOR-AS134N70	AS-134 O-Ring	1pcs
4	2P002-SOR-S55N70	S-55 O-Ring	1pcs
5	2P001-D4N0M4-0706	PEEK M4xP0.7x6 Socket Grub Screw	2pcs
6	2P002-SOR-S7N70	S-7 O-Ring	2pcs

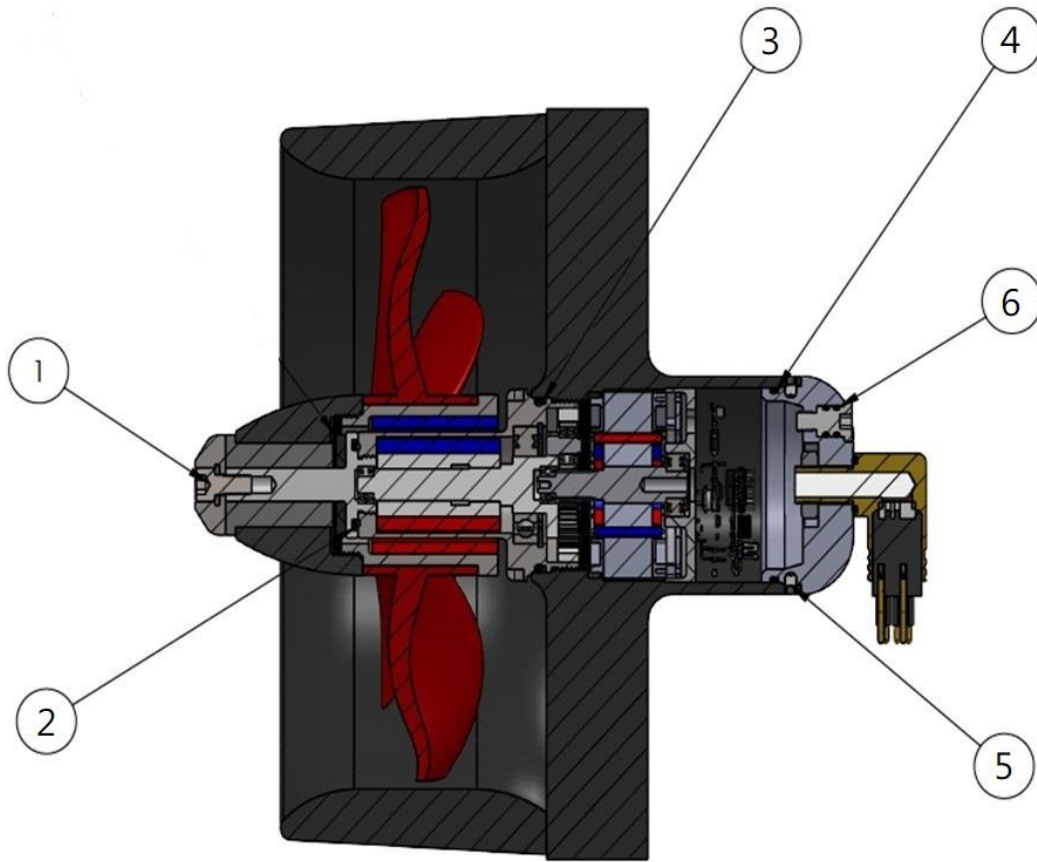
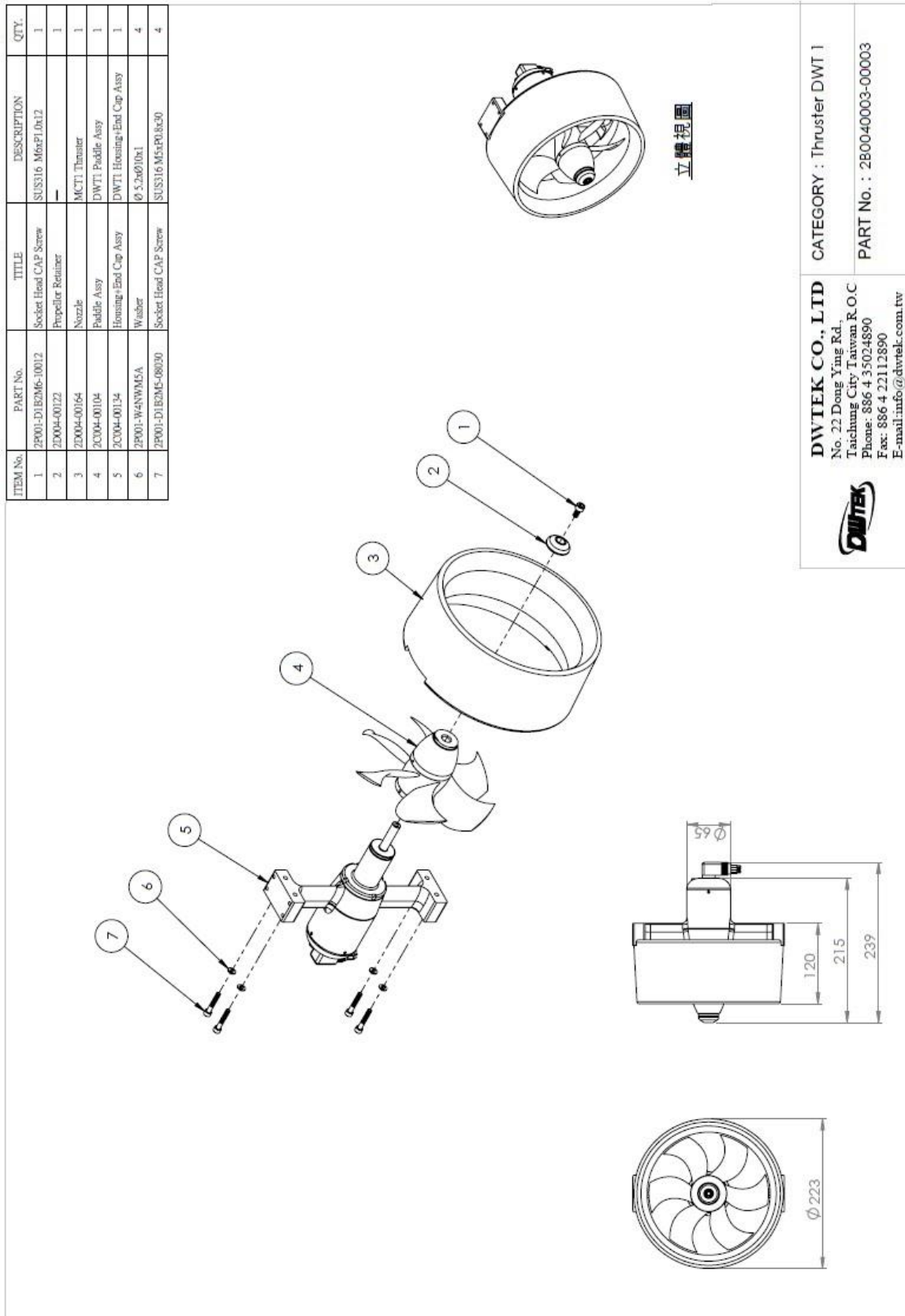

Figure 4 - DWT 1 Thruster Spares

Table 6 - Tools list

Item No.	Part No.	Description	Qty
1	2P001-FLU5M2	M2 Allen Key	1pcs
2	2P001-FLU5M4	M4 Allen Key	1pcs
3	2P999-00027	58-62mm Hook Wrench	1pcs

6.3 Exploded View



VI.0

Figure 5 - DWT 1 Thruster (2B0040003-00003)

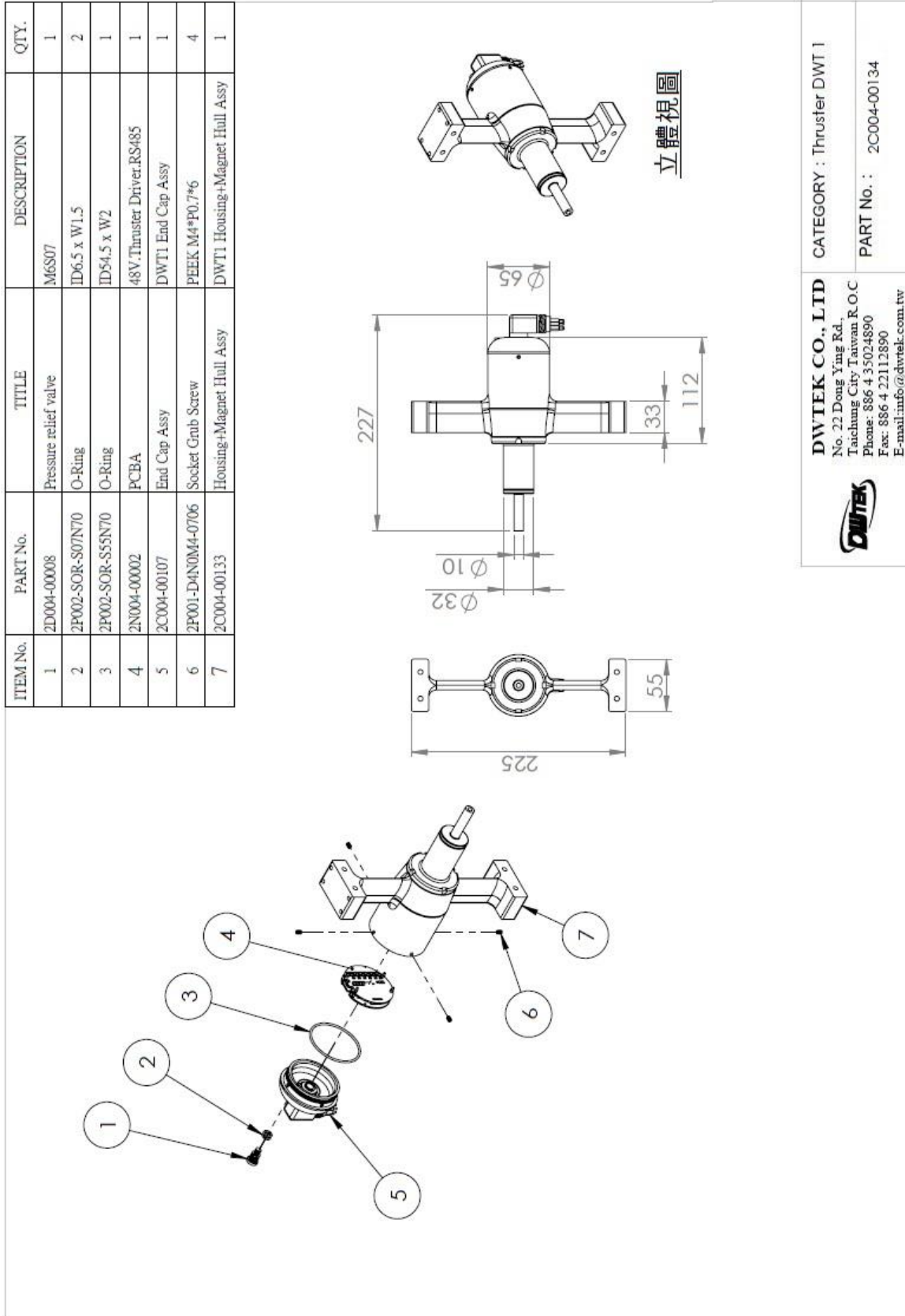

DWTEK CO., LTD
 No. 22 Dong Ying Rd.
 Taichung City Taiwan R.O.C
 Phone: 886 4 35024890
 Fax: 886 4 22112890
 E-mail: info@dwitek.com.tw

CATEGORY : Thruster DWT 1
 PART No. : 2C004-00134

V1.0

Figure 6 – Housing + End Cap Assy (2C004-00134)

ITEM No.	PART No.	TITLE	DESCRIPTION	QTY.
1	2C004-00131	Housing+Motor Stator Assy	DWT1 Housing+Motor Stator Assy	1
2	2C004-00132	Motor Stator+ Gear Shaft Assy	DWT1 Motor Stator+ Gear Shaft Assy	1
3	2C004-00105	Reducer + Magnet Hull Assy	DWT1 Reducer + Magnet Hull Assy	1
4	2D004-00029	Motor Front End Bearing Cap	for 500W thruster	1
5	2P001-WW5512	Wave Washer	WW-12 (12.5x17x2.5)	1
6	2P007-698ZZ NMB	Ball Bearing	OD19 x ID8 x 6	1
7	2P002-SOR-AS134N70	O-Ring	ID47.29 x W2.62	1

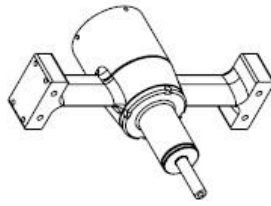
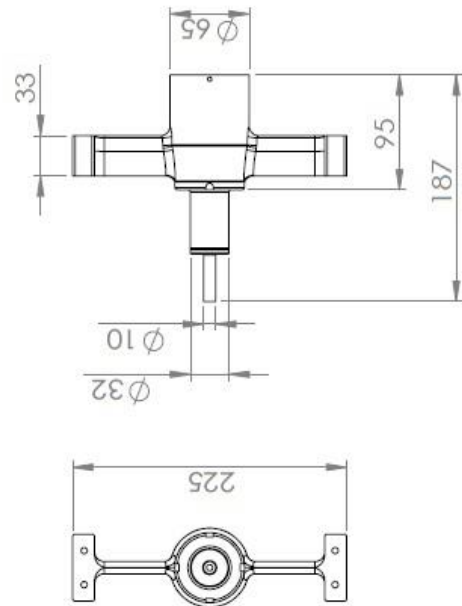
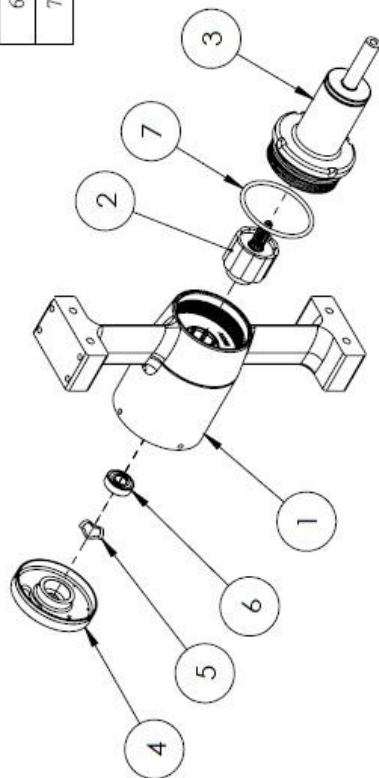

立體視圖

DWTEK CO., LTD
 No. 22 Dong Ying Rd.,
 Taichung City, Taiwan, R.O.C
 Phone: 886 4 35024890
 Fax: 886 4 22112890
 E-mail: info@dwtek.com.tw



CATEGORY : Thruster DWT 1
 PART No. : 2C004-00133

Figure 7 – Housing + Magnet Hull Assy (2C004-00133)

ITEM No.	PART No.	TITLE	DESCRIPTION	QTY.
1	2GW100708M-00001	Mini Bulkhead Right Angle Connector	Male 8 Pin	1
2	2D004-00163	End Cap	Ø65x30L	1
3	2F001-N122U716A-T20	Hex Nut	SUS304 7/16"-T20	1

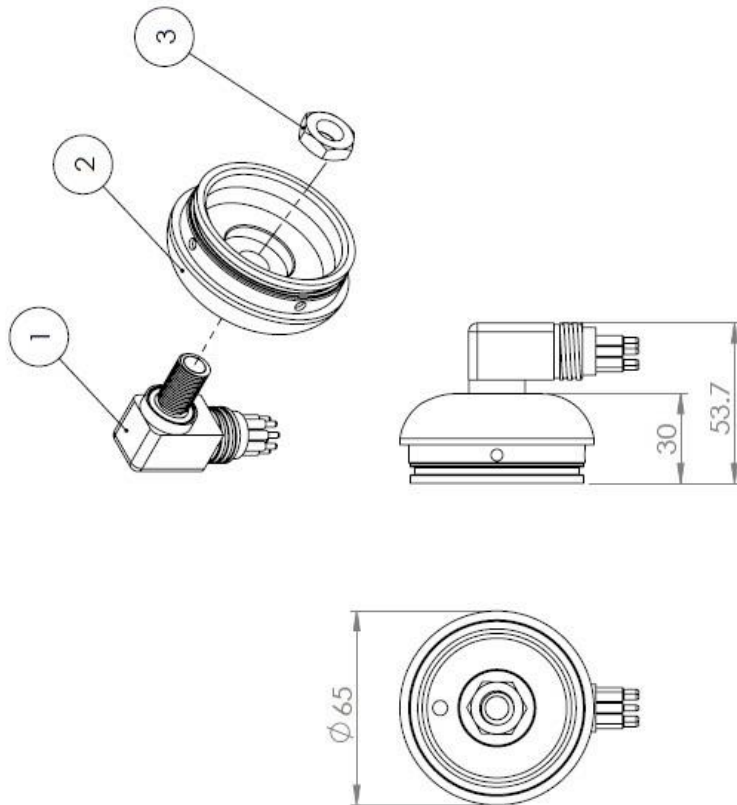

	DWTEK CO., LTD No. 22 Dong Ying Rd., Taichung City, Taiwan R.O.C Phone: 886 4 35024890 Fax: 886 4 22112890 E-mail: info@dwtek.com.tw	CATEGORY : Thruster DWT 1
		PART No. : 2C004-00107

V1.0

Figure 8 - End Cap Assy (2C004-00107)

ITEM No.	PART No.	TITLE	DESCRIPTION	QTY.
1	2C004-00103	Magnet Hull Assy	DWT1 Magnet Hull Assy	1
2	2C004-00066	Magnet Driver Rotor	DWT1 JTL	1
3	2P007-16003ZZKSK	Ball Bearing	OD35 x ID17 x 8	1
4	2P001-AR5535	Circlip	R35	1
5	2C004-00065	Planetary Gear Assy	MCT1 JTL	1

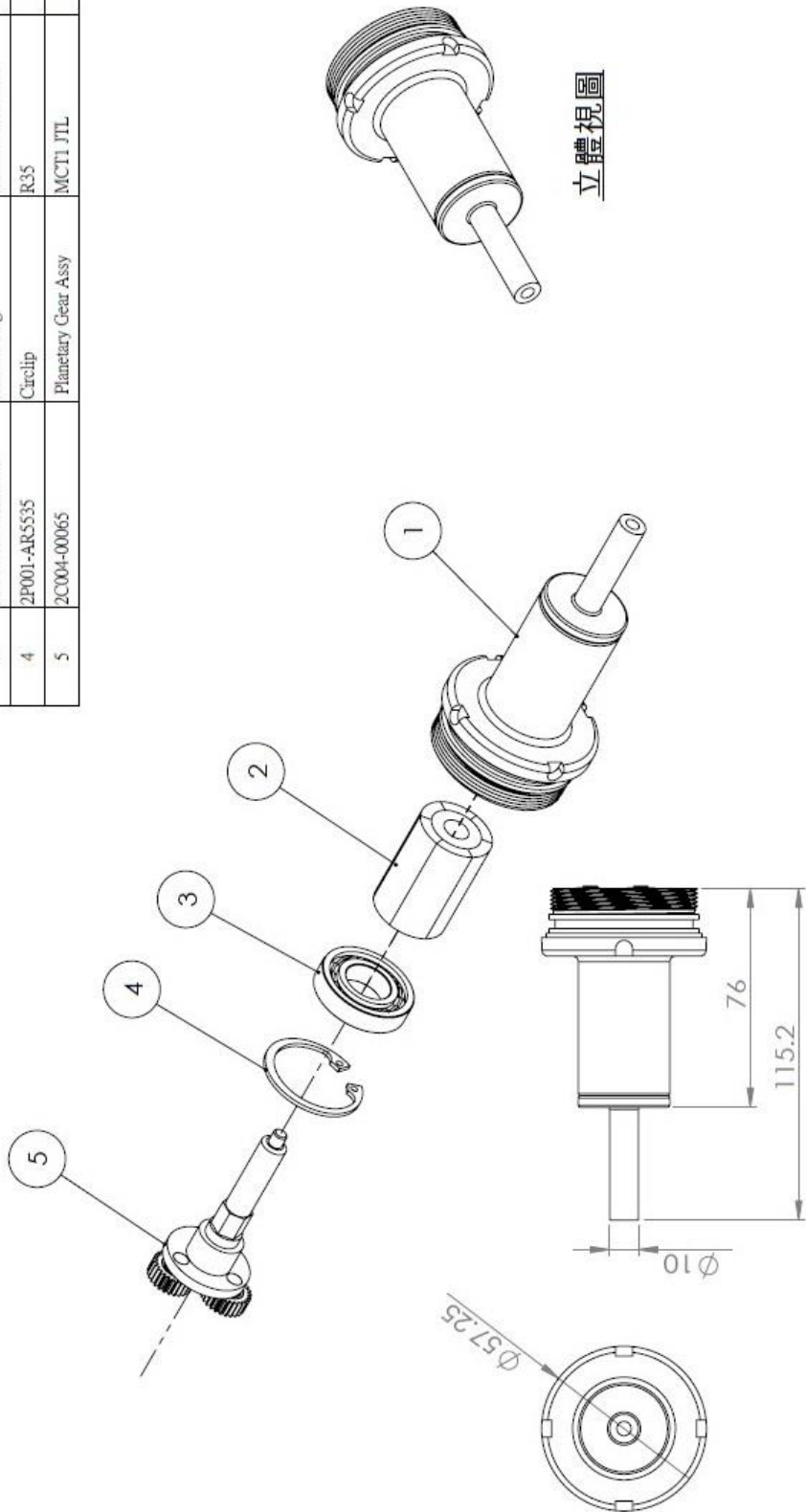



DWTEK CO., LTD
 No. 22 Dong Ying Rd.
 Taichung City, Taiwan R.O.C
 Phone: 886 4 55024890
 Fax: 886 4 22112890
 E-mail: info@dwitek.com.tw

CATEGORY : Thruster DWT 1
 PART No. : 2C004-00105

Figure 9 - Reducer + Magnet Hull Assy (2C004-00105)

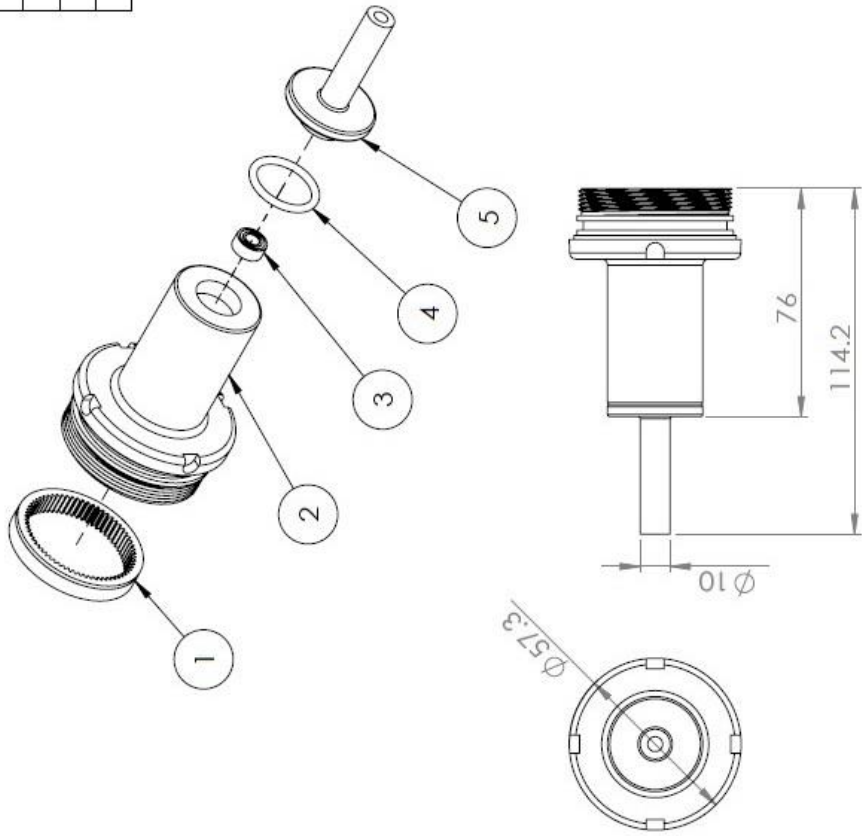
ITEM No.	PART No.	TITLE	DESCRIPTION	QTY.
1	2D004-00113	Inner Gear	0.6M 65T	1
2	2D004-00111	Gear & Magnet Hull	MCT1	1
3	2P007-685ZZ KOYO	Ball Bearing	OD11 x ID5 x 5	1
4	2P002-SOR-AS117N70 AS-117		ID20.29 x W2.62	1
5	2D004-00166	Prop Axle	DWT1 Prop Axle	1



	DWTEK CO., LTD No. 22 Dong Ying Rd. Taichung City Taiwan, R.O.C Phone: 886 4 35024890 Fax: 886 4 22112890 E-mail: info@dwitek.com.tw	CATEGORY : Thruster DWT 1
	PART No. : 2C004-00103	

Figure 10 - Magnet Hull Assy (2C004-00103)

6.4 RS485 Signal Control

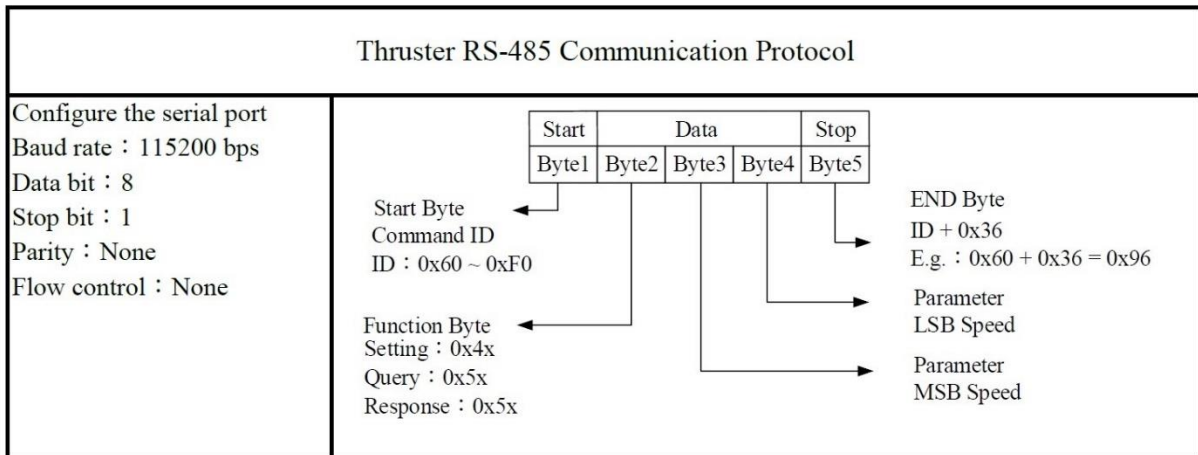

Figure 11 - Thruster RS-485 Communication Protocol

*Setting for CW/CCW Speed & ID			
Command Set	Command	Command Packet	Comments
	CW Speed	60 41 03 E8 96	$03E8_{16} = 1000 \text{ RPM}$
	CCW Speed	60 42 17 70 96	$1770_{16} = 6000 \text{ RPM}$
	Stop	60 40 00 00 96	$0000_{16} = 0000 \text{ RPM}$
	ID	F0 4F 00 61 AA	Set unknown device , ID = 0xF0 , END = 0xAA "0x61" is symbol for ID.
Setting	<p style="text-align: center;">Setting CW/CCW Speed</p> <p style="text-align: center;">E.g. 0x60 0x41 0x03 0xE8 0x96</p> <p>Command ID ← 0x60 END Byte 0x60 + 0x36 = 0x96</p> <p>Setting Function ← 0x41 Setting Speed $(03E8)_{16} = (1000)_{10} \text{RPM}$</p> <p style="text-align: center;">Setting ID to 0x7A</p> <p style="text-align: center;">E.g. 0xF0 0x4F 0x00 0x7A 0xAA</p> <p>Command ID ← 0xF0 END Byte</p> <p>Setting ID ← 0x4F Setting ID : 0x7A</p> <p style="text-align: center;">Example of setting CW/CCW Speed after ID has been changed</p> <p style="text-align: center;">E.g. 0x7A 0x41 0x03 0xE8 0xB0</p> <p>Command ID ← 0x7A END Byte 0x7A + 0x36 = 0xB0</p> <p>Setting Function ← 0x41 Setting Speed $(03E8)_{16} = (1000)_{10} \text{RPM}$</p>		

Figure 12 - Setting for CW/CCW Speed & ID

*Query for Speed & ID			
Command Set	Command	Command Packet	Comments
Query	Speed	60 50 00 00 96	Ask Speed
	ID	F0 5F 00 00 AA	Ask unknown device , ID = 0xF0 , END = 0xAA
<p style="text-align: center;">Response Speed</p> <p style="text-align: center;">E.g. 0x60 0x50 0xXX 0xXX 0x96</p> <p>Command ID ← 0x60 END Byte 0x60 + 0x36 = 0x96</p> <p>Response Function Speed : 0x50 0xXX Response Value</p> <p style="text-align: center;">Query ID</p> <p style="text-align: center;">E.g. 0xF0 0x5F 0x00 0x00 0xAA</p> <p>Command ID ← 0xF0 END Byte</p> <p>Query ID Function : 0x5F N/A always 0x00</p>			
NOTE : When query thruster IDs, please refer to the Response command set.			

Figure 13 - Query for Speed & ID

*Response for Speed & ID			
Command Set	Command	Command Packet	Comments
Response	Speed	60 50 03 E8 96	e.g. Speed : 03E8 ₁₆ = 1000 RPM
	ID	F0 5F 00 61 AA	"0x61" is symbol for ID.
<p style="text-align: center;">Response Speed</p> <p style="text-align: center;">E.g. 0x60 0x50 0xXX 0xXX 0x96</p> <p>Command ID ← 0x60 END Byte 0x60 + 0x36 = 0x96</p> <p>Response Function Speed : 0x50 0xXX Response Value</p> <p style="text-align: center;">Response ID</p> <p style="text-align: center;">E.g. 0xF0 0x5F 0x00 0x61 0xAA</p> <p>Command ID ← 0xF0 END Byte 0xAA</p> <p>Response Function ID : 0x5F Response ID : 0x61</p>			

Figure 14 - Response for Speed & ID



The information contained in this document is subject to be modified and/or supplemented from time to time by DWTEK Co., Ltd without prior notice.

DWTEK Co., Ltd shall not be liable for any loss, errors or damage in connection with information in this document.

Copyright © 2023 DWTEK Co., Ltd. All rights reserved.