



Operator's Manual

DWT085G1-300V Thruster

2T01-00022 24/01

DWTEK Co., Ltd

No.22, Dong Ying Rd., East District, Taichung City 401, TAIWAN

T: +886-4-3502-4890 | E: info@dwtek.com.tw

F: +886-4-2211-2890 | W: www.dwtekmarine.com

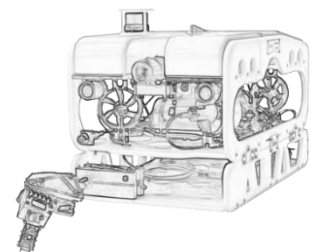



Revision information

Issue	Revisions	Date	Revised	Approver
1	First edition	2024/1/25	LIAO YU TSO	Mike Chen



Table of Contents

1	Introduction	6
1.1	General.....	6
1.2	Precautions	7
2	Specifications.....	8
2.1	Thruster	8
2.2	Connector.....	10
2.2.1	General.....	10
2.2.2	Indications for Replacement	10
2.2.3	Cleaning Procedure.....	10
3	Installation.....	11
3.1	Installation Guide.....	11
3.2	Pin Assignment	11
3.3	Maintenance and Removal.....	13
4	Trouble shooting	14
4.1	Thruster Trouble shooting	14
4.2	Detection Procedure.....	14
5	Maintenance.....	15
5.1	Nozzle	15
5.1.1	General.....	15
5.1.2	Indications for Replacement	15
5.1.3	Removal the Nozzle from Thruster `	15
5.2	Propeller Assembly	16
5.2.1	General.....	16
5.2.2	Indications for Replacement	16
5.2.3	Removal Procedures	16
5.2.4	Install Procedures	16
5.3	Gear Shaft Seal Assy.....	17
5.3.1	General.....	17
5.3.2	Indication for Replacement.....	17
5.3.3	Installation Procedures of Gear Motor Seal Cap Assy	17
6	Oil Filled and Drain.....	19
7	Appendix.....	25
7.1	Vacuum and Pressure Relief	25
7.2	Spares and Tools.....	26
7.3	Exploded View.....	27



List of Figures

Figure 1 - DWT085G1 Thruster	8
Figure 2 - DWT085G1 Thruster performance curve	9
Figure 3 - DWT085G1 Thruster Pin Assignment	12
Figure 4 - The Seal Parjet HiperLip (P/N 2P014- NH-022-5-8-X)	17
Figure 5 - Correct Fitting Place	18
Figure 6 - Oil Filled-1	20
Figure 7 - Oil Filled-2	20
Figure 8 - Oil Filled-3	21
Figure 9 - Oil Filled-4	21
Figure 10 - Oil Filled-5	22
Figure 11 - Oil Filled-6	22
Figure 12 - Drain Procedure-1	24
Figure 13 - Drain Procedure-2	24
Figure 14 - DWT085G1 Thruster Sectional view.....	26
Figure 15 - DWT085G1 Thruster (2B0040006-00004).....	27
Figure 16 - Reducer Assembly (2C004-00083).....	28
Figure 17 - Shaft Reducer Assembly (2C004-00084).....	29
Figure 18 - End Cap Assy (2C004-00100)	30



List of Tables

Table 1 - Precautions.....	7
Table 2 - DWT085G1 Specification	8
Table 3 – DWT085G1 Thruster Electrical	11
Table 4 - Pin Assignment	11
Table 5 - Spares list.....	26
Table 6 - Tools list.....	26



1 Introduction







1.1 General

DWTEK releases new range of brushless DC thrusters with the outstanding characters of low-weight, powerful thrust and integral electronic components. The engineering capabilities of DWTEK in subsea application drive our passion to innovate high reliable design and components to our thrusters.

DWT085G1 thruster is a heavy-duty electric underwater thruster. The design is in purpose of high efficiency and low noise stealth; meanwhile it is suitable the propulsion system of any underwater robots or high-end surface utility vehicles.

1.2 Precautions

Table 1 - Precautions

	<p>The “DANGER” symbol indicates a hazardous situation which, if not avoided, will result in death or serious injury. Carefully read the message that follows to prevent serious injury or death.</p>
	<p>The “WARNING” symbol indicates a hazardous situation which, if not avoided, could result in death or serious injury. Carefully read the message that follows to prevent serious injury or death.</p>
	<p>The “CAUTION” symbol indicates a hazardous situation which, if not avoided, could result in minor or moderate injury, or equipment damage. Carefully read the message that follows to prevent minor or moderate injury.</p>
	<p>The “NOTICE” symbol alerts to a situation that is not related to personal injury but may cause equipment damage</p>
	<p>Do not put hands near it when machine operating.</p>
	<p>Do not wear electrically conductive jewelry, clothing, or other items while working on the electrical system.</p>
	<p>An electric shock could be fatal. Ensure power to the Thruster is OFF” before opening electrical panels.</p>

2 Specifications

2.1 Thruster

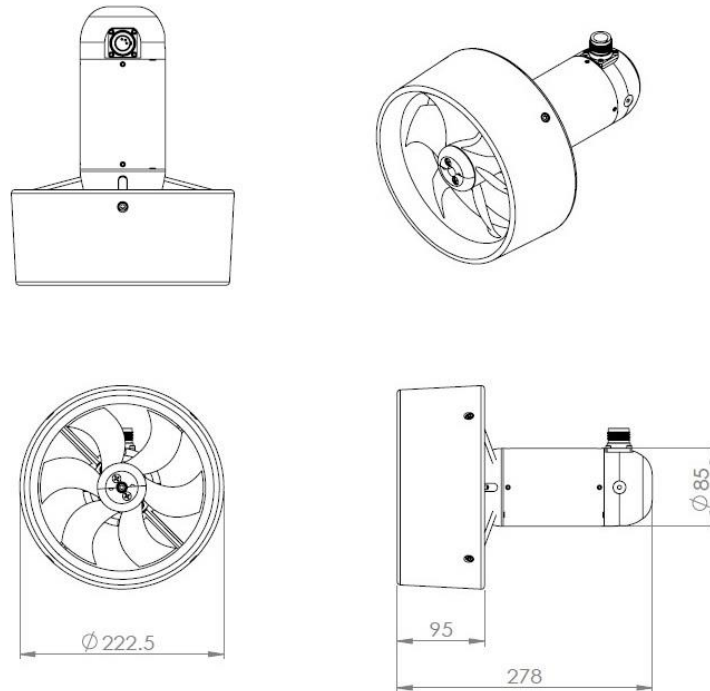

Figure 1 - DWT085G1 Thruster

Table 2 - DWT085G1 Specification

DWT085G1	
MECHANICAL	
Weight in air	4.6 kg
Weight in water	2.3 kg
Standard Housing	AL 6061-T6
Propeller	Engineering Plastic
Nozzle	Nylon
ELECTRICAL	
Operation Voltage	300 VDC
Speed Control	±5V
Drive	Direct Drive
Watt	1000W
Protection	Over-Temp / Over Current / Under Voltage / Abnormal Operation
PERFORMANCE	
Thrust	CW: 24 kgf / CCW: 23 kgf

DWT085G1-300V_1000W

THRUST PERFORMANCE CURVES

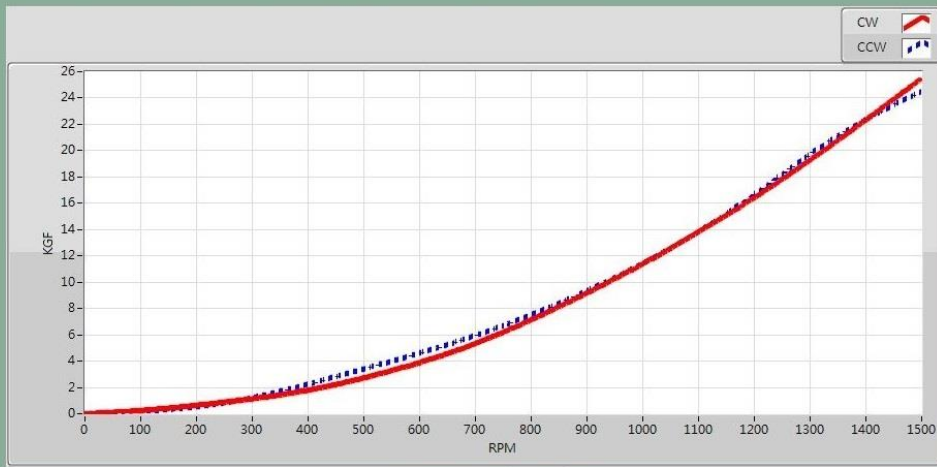

RPM VS KGF

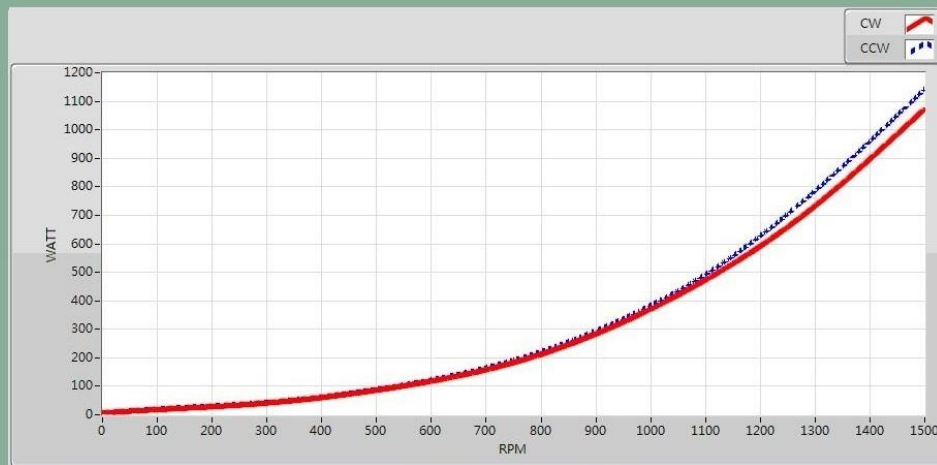

RPM VS WATT

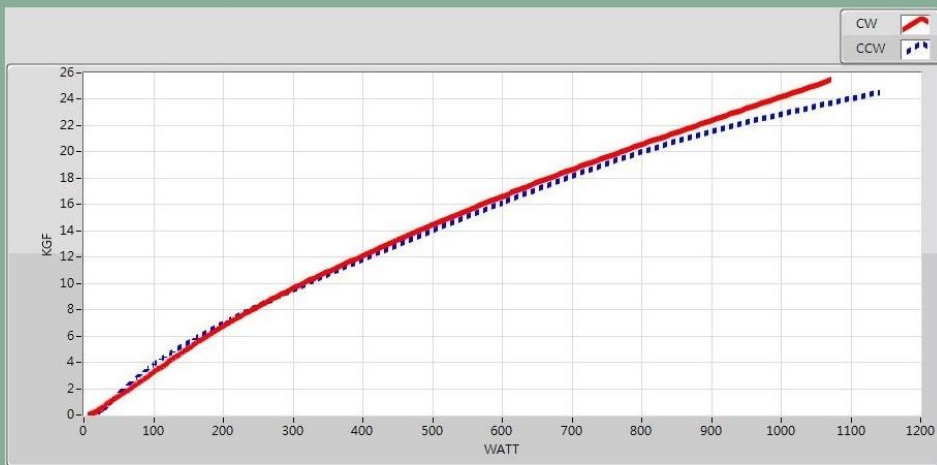

WATT VS KGF

Figure 2 - DWT085G1 Thruster performance curve



2.2 Connector

2.2.1 General

Part No.	2GM170308M-00001
Title	Metal Shell G Flange Connector
Service Check	Regularly

2.2.2 Indications for Replacement

Replace if connector is damaged, deformed or no longer watertight.

2.2.3 Cleaning Procedure

General cleaning and removal of any accumulated sand or mud on a connector should be performed with spray based contact cleaner, Isopropyl Alcohol.



Warning!!

Only the qualified specialist is allowed to proceed the connector replacement.

3 Installation

3.1 Installation Guide

Table 3 – DWT085G1 Thruster Electrical

	Nominal	Max	Min
Input Voltage	300 VDC	315 VDC	285 VDC
Input Current	3.34A	3.18A	3.51A
Instrument Power Voltage	15V	16.5V	13.5V
Instrument Power Current	0.12A	0.11A	0.14A
Analog	+/- 5V	+/- 6V	

Procedure of electronic Connection:

Step1. Connect Pin3 to +300 VDC

Step2. Connect Pin1 to HGnd

Step3. Connect Pin5 to +/- 5V

Step4. Connect Pin7 to +/- 5V ISO GND

Step5. Connect Pin4 to +15 VDC (instrument)

Step6. Connect Pin1 to HGnd (instrument 15 VDC)

Step7. Connect Pin2 to Protection Earth point where available

3.2 Pin Assignment

Table 4 - Pin Assignment

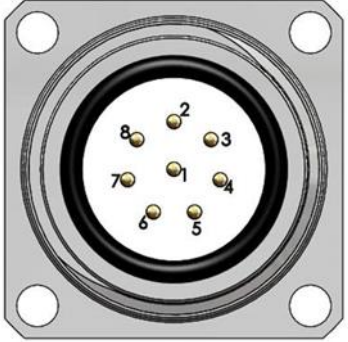
Female Inline Top View	Pin Assignment	Male Bulkhead Top View
	1 : HGnd 2 : PE 3 : +300 VDC 4 : +15 VDC 5 : +/- 5V 6 : N/A 7 : ISO GND 8 : N/A	

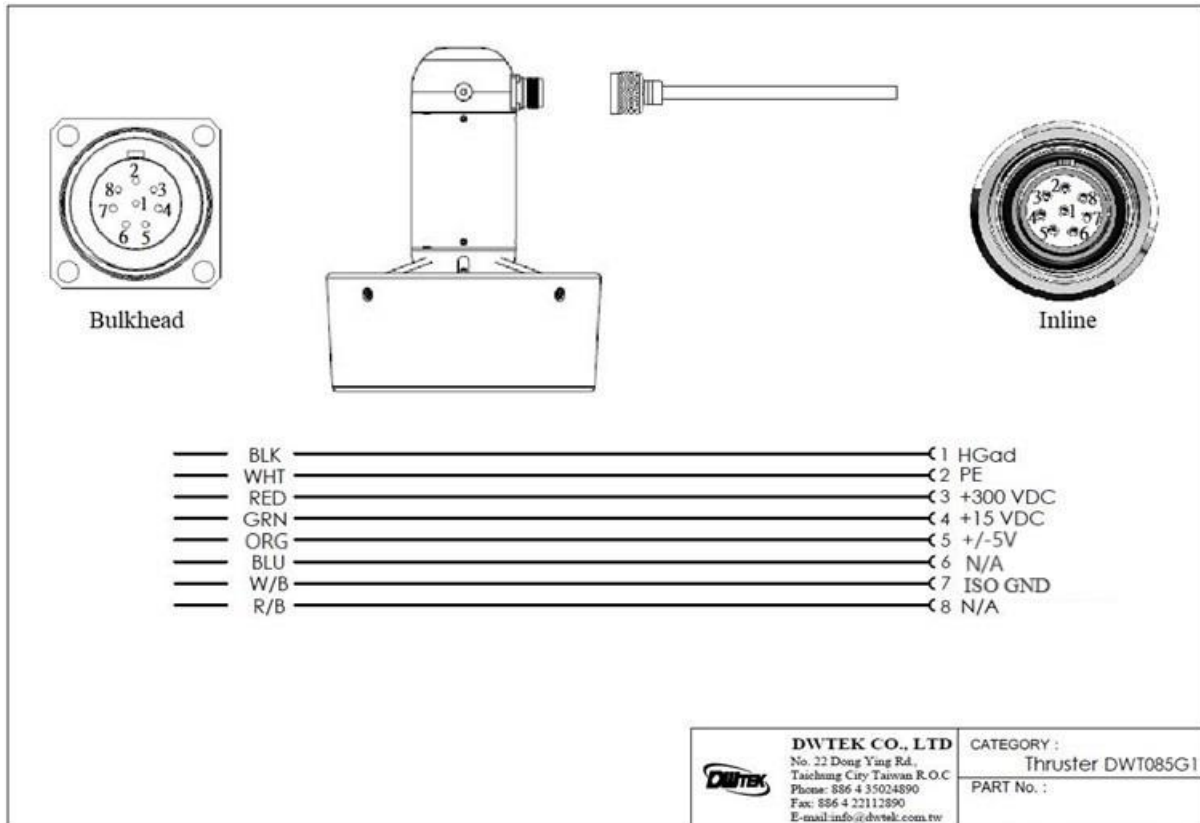

Figure 3 - DWT085G1 Thruster Pin Assignment

Make sure all the connections are correct, and follow the instruction listed as below to power the thruster.

1. Connect Pin2 to the Protection Earth point
2. Deliver +15 VDC to Pin4 and Pin1
3. Deliver +/- 5V control signal to Pin5 and Pin7
4. Make sure +/- 5V control signal is set within +/- 0.2VDC
5. Deliver +300 VDC to Pin3 and Pin1
6. Adjust +/- 5V control signal to Pin5 and Pin7
7. Thruster should turn CW and CCW based on the apply voltage polarity

Note!!



1. Control signal is set as 0 RPM within +/- 0.2VDC.
2. Always make sure to set the control signal within +/- 0.2VDC before powering on 300Vdc to the thruster. Failure to do so would result in the thruster not being activated because of the safety startup procedure.
3. The WATT of DWT085G1 at the maximum speed is about 1000W±5%.
4. After the thruster powers on, DO NOT REMOVE the control +/- 5V, otherwise the speed will be abnormal.



3.3 Maintenance and Removal

To remove the thruster, please follow below steps.

1. Disconnect the cable.
2. Install the protection dummy on the bulkhead connector

THRUSTER FIELD & DEPOT REPAIR PROCEDURES LISTED BELOW SHALL BE CARED.



Warning!!

Make sure to switch off thruster power and auto-functions once the system is on the surface.



Caution!!

It recommends considering the replacement of the O-rings and resealing DWT085G1 thruster as annual maintenance. DWTEK offers comprehensive annual inspection and maintenance service to guarantee reliability and performance.



Caution!!

The thruster is designed as a simple maintenance unit. After each dive, please always wash with fresh water.

4 Trouble shooting

4.1 Thruster Trouble shooting

If thruster performed:

- I. RPM unsteady.
- II. Vibration.

please proceed the initial detection procedure which mainly caused by two type of cases as below:

- I. Power output.
- II. Consumption parts and determine the replacement.

4.2 Detection Procedure

1. Make sure the propeller is free of rotation and under safety and well protection.
2. Apply +15 VDC to Pin4 and HGnd to Pin1. It recommends using power supply with the current consumption indicator. The nominal current consumption is 0.12Amp +/- 0.02.
If current consumption is out of the above range without loading, the control PCB need to be examined and replaced.
3. Measure the analog input +/- 5V with multimeter and make sure +/- 5V is connected to Pin5 and Pin7 ISO GND.
4. Apply input voltage +300 VDC to Pin3 and HGnd to Pin1.
5. Make sure +/- 5V signal is within +/- 0.2V before delivering +300 VDC to thruster.
6. Use a current indicator to wire on the power supply in series before delivering +300 VDC.
7. Make sure current output is less than 0.1A when signal is 0V.



Caution!!

If the current goes higher with short circuit, the power PCB need to be examined and replaced, please do not hesitate to contact DWTEK Co., Ltd.



5 Maintenance

5.1 Nozzle

5.1.1 General

Part No.	2D004-00058
Title	Nozzle
Service Check	Replace if damaged
Tool	4mm Allen Key

The nozzle is designed to improve the performance in water. Without the nozzle, there would be a drastic thrust reduction and control failure. Thruster can be tested in air but it recommends contacting DWTEK if doing enforced dummy load in the shaft of thruster.

The nozzle consists of a cast Nylon material that is high impact-resistant.

5.1.2 Indications for Replacement

Please replace the nozzle if it damages to the point that it fouls the propeller.

5.1.3 Removal the Nozzle from Thruster`

1. Remove (4) SS Socket Head Cap Screw M5x80mm (P/N 2D004-00014) with 4mm Allen Key.
2. Remove (4) Support Rod (P/N 2D004-00051) in the Nozzle.

Installation Procedures

1. Install (4) Support Rod (P/N 2D004-00051). Make sure to align the hole in the Nozzle.
2. Put (4) SS Socket Head Cap Screw M5x80mm (P/N 2D004-00014) into Nozzle through Support Rod.
3. Secure screws with 4mm Allen Key(4.2NM).



NOTE!!

If you have any further queries, please do not hesitate to contact DWTEK Co., Ltd.

5.2 Propeller Assembly

5.2.1 General

Part No. :	2P005-SET0089
Title :	Vectus Propeller
Service Check :	Before and after each dive
Tool	1. Screw Driver 2. 4mm Allen Key

DWT085G1 thruster uses Vectus propeller that has outstanding thrust performance in operation. The thrust differences between forward and reverse thruster are within 10%.

5.2.2 Indications for Replacement

Replace it if significant wear or damage is apparent on the blades of the propeller.

5.2.3 Removal Procedures

1. Unscrew SS Socket Head Cap Screw M5x10mm (P/N 2P001-D122M5-08010) with 4mm Allen Key and washers (P/N 2P001-W422M5A and 2P001-W4NWM5A).
2. Unscrew (2) tap screws and remove (2) propeller caps.
3. Remove dowel pin and propeller from the shaft.

5.2.4 Install Procedures

1. Insert Pin 4x24mm into Shaft
2. Install Propeller onto shaft and confirm Pin touch on the Propeller groove.
3. Secure SS Socket Head Cap Screw M5x10mm (P/N 2P001-D122M5-08010) and washer (P/N 2P001-W422M5A and 2P001-W4NWM5A) to Vectus SET0089 propeller with 4mm Allen Key(4.2NM).



Warning!!

Operator is only allowed to remove propeller assembly under power off condition.



NOTE!!

If you have any further queries, please do not hesitate to contact DWTEK Co., Ltd.

5.3 Gear Shaft Seal Assy

5.3.1 General

Part No. :	2C004-00083
Title :	Reducer Assembly
Service Check :	Before and after each dive
Tool :	1. Screw Driver 2. 4mm Allen Key

The rotation shaft was sealed by 2 opposite rotary seals (Seal Parjet HiperLip, P/N 2P014-NH-022-5-8-X). Both seals may be worn out after certain period under different circumstance or operation. Operator needs to check the sealing condition before and after each dive. If any damage or leaking are detected, please follow the following instruction on inspection and component replacement.

5.3.2 Indication for Replacement

Replace Seal Parjet HiperLip (P/N 2P014- NH-022-5-8-X) if damage or leaking is detected

1. Replace in annual service.
2. Replace if leaking.

5.3.3 Installation Procedures of Gear Motor Seal Cap Assy

1. Press first piece of Seal Parjet HiperLip (P/N 2P014- NH-022-5-8-X) into Gear Motor Seal Cap (P/N 2D004-00061) by face up.
2. Press second piece of Seal Parjet HiperLip (P/N 2P014- NH-022-5-8-X) into the Cap by face down.
3. Install O-ring (P/N 2P002-SOR-AS020N70) and (P/N 2P002-SOR-AS130N70) into the Cap.



Figure 4 - The Seal Parjet HiperLip (P/N 2P014- NH-022-5-8-X)



Figure 5 - Correct Fitting Place

5.3.4 Dis-Assembly Procedure

1. Please refer to section 1.4 to remove the Nozzle.
2. Please refer to section 1.6 to remove the propeller.
3. Remove the Pin 4x24mm.
4. Unscrew (4) SS Socket Head Cap Screw M5x10mm (P/N 2P001-D122M5-08010) with 4mm Allen Key.
5. Lift Gear Motor Seal Cap Assy (P/N 2C004-00043) with flat Screwdriver.
6. Push out (2) Seal Parjet HiperLip (P/N 2P014- NH-022-5-8-X) from Gear Motor Seal Cap (P/N 2C004-00043) and remove O-ring (P/N 2P002-SOR-AS020N70) and (P/N 2P002-SOR-AS130N70).

5.3.5 Installation Procedure

1. Use 4mm Allen Key to secure (4) SS Socket Head Cap Screw M5x10mm (P/N 2P001-D122M5-08010) and Gear Motor Seal Cap (P/N 2C004-00043).
2. Insert Pin 4x24mm into Shaft.
3. Please refer to 1.6.4 to Installation Propeller.



NOTE!!

It suggests Operator attach plastic washer with SS Socket Head Cap Screw.



NOTE!!

If you have any further queries, please do not hesitate to contact DWTEK Co., Ltd



6 Oil Filled and Drain

DWT085G1 Thruster needs to be oil filled in order to cool the high performance electric devices and increase the reliability of thruster for underwater operation. The inlet port is at the opposite side of the MG8M-FCR connector and outlet port is 90 degrees beside the connector. The oil-filled and drain operation may involve few skills and concepts. If anything in doubt, please feel free to contact manufacturer for instruction.

Warning!!

Morlina S2 BL or equivalent - Avoid prolonged and repeated touch with skin.



If swallowed, call a poison Control Centre or doctor immediately. Please contact the Oil manufacturer or distributor to request Safety Data Sheet and always read the Safety Data Sheet before operation.

6.1 Oil Filled

1. Put Thruster horizontally and direct the outlet port to be face up and slightly higher than thruster housing to extraction air out.

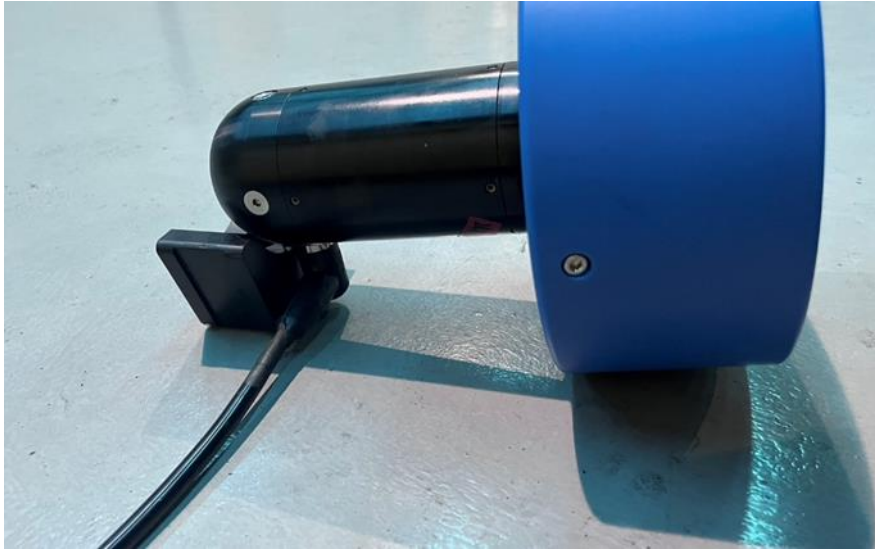

Figure 6 - Oil Filled-1

2. Release both Pressure Relief Valves (P/N 2D004-00158 ,2D003-00016).
3. Tighten the fitting valve with hose on inlet port.



Figure 7 - Oil Filled-2

4. Fill compensation oil into a syringe then insert the plain tip into the hose
5. Inject compensation oil into thruster (around 220cc) (See Tip 1)

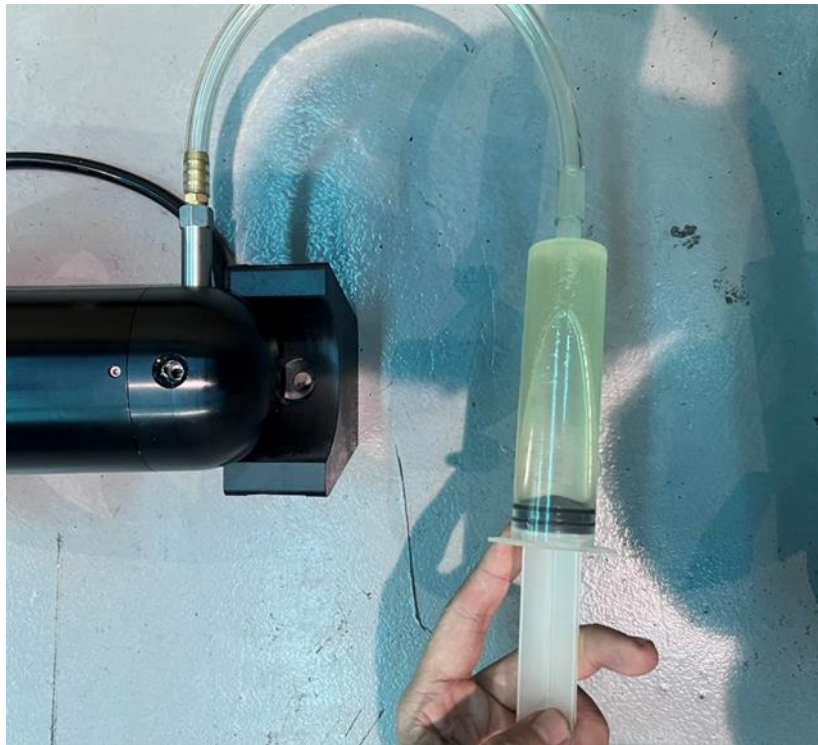

Figure 8 - Oil Filled-3

6. When oil comes out from the outlet valve, lift and down thruster nozzle few times to help air escape out of thruster.



Figure 9 - Oil Filled-4

7. Tighten the Pressure Relief Valve (P/N 2D004-00158) on outlet port then turns inlet port to face up.
8. Press plunger to pump and enforce compensation oil into thruster housing until the diaphragm bulged.



Figure 10 - Oil Filled-5

9. Retrieve plunger to suck compensation oil and lift and down thruster housing few times to help air escape out of thruster. Repeat this process several time in order to exhaust air from the thruster.



Figure 11 - Oil Filled-6

10. Remove the syringe and unscrew the fitting valve.
11. Secure the Pressure Relief Valve (P/N 2D003-00016) on inlet port.
12. Clean the table, bracket and thruster.

13. Visible leaking inspection.



Warning!!

Operator is required to wear the protection gloves and glass before start the oil fill operation.



Caution!!

Operator may use vacuum pump to test the sealing condition. Please refer to Appendix.



6.2 Drain Procedure

1. Upside down the Thruster to drain the polluted compensation oil.



Figure 12 - Drain Procedure-1

2. Release both Pressure Relief Valves (P/N 2D004-00158 ,2D003-00016) and drain the compensation oil.

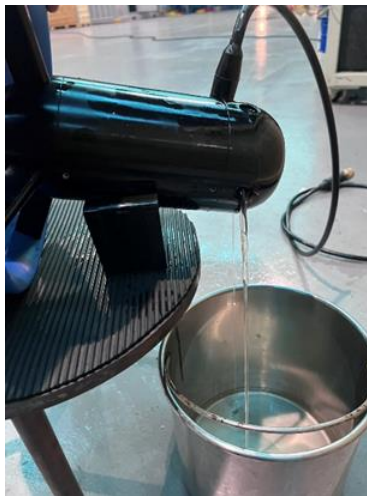

Figure 13 - Drain Procedure-2

3. Secure both Pressure Relief Valve (P/N 2D004-00158 ,2D003-00016) if no longer oil drained.



Caution!!

Visible inspection to electric driver and make sure no burned mark, loose/disconnected wire or damage. If any, please contact manufacturer.

Caution!!

Dispose polluted oil according to local regulation and protect the environment responsibly.

7 Appendix

7.1 Vacuum and Pressure Relief

All electronic components could generate heat and prohibit system operation with a vacuum condition. Pressure relief port can be used as a vacuum port for testing purpose.

Recommended vacuum test on the pod is -80kPa for a period of 30 to 60 minutes after disassemble and re-assembly. It should be released once the testing is complete. Filling in Nitrogen gas from the Nitrogen bottle with an adaptor would take out the moisture to prevent concentration.

Warning!!



- 1. Make sure that this process was carried out in a well-organized place.**
- 2. Check and clean the O-rings on pressure relief valve before installation. If they are damaged, please replace it with new one, and greased with Silicone Grease.**

7.2 Spares and Tools

Table 5 - Spares list

Item No.	Part No.	Description	Qty
1	2P001-D4N0M5-0806	M5xP0.8x6 Socket Grub Screw	2pcs
2	2P001-D122M5-08010	M5xP0.8x10 Socket Head CAP Screw	1pcs
3	2P001-D1B2M5-08016	SUS316 M5xP0.8x16 Socket Head CAP Screw	1pcs
4	2D003-00016	5/16"xT24 Pressure relief valve	1pcs
5	2D004-00158	5/16"xT24 Pressure relief valve	1pcs
6	2P002-SOR-AS012N70	ID9.25 x W1.78 AS-012 O-ring	1pcs
7	2P002-SOR-AS020N70	ID21.95 x W1.78 AS-020 O-ring	1pcs
8	2P002-SOR-AS130N70	ID40.95 x W2.62 AS-130 O-ring	2pcs
9	2P002-SOR-AS148N70	ID69.52 x W2.62 AS-148 O-ring	1pcs
10	2P002-SOR-AS149N70	ID71.12 x W2.62 AS-149 O-ring	1pcs
11	2P001-W422M5A	SUS304 Ø 5.2x10x1 Washer	1pcs
12	2P001-W4NWM5A	Ø 5.2xØ10x1 Washer	1pcs
13	2P007-7203ZZKOYO	Seal Parjet HiperLip	1pcs

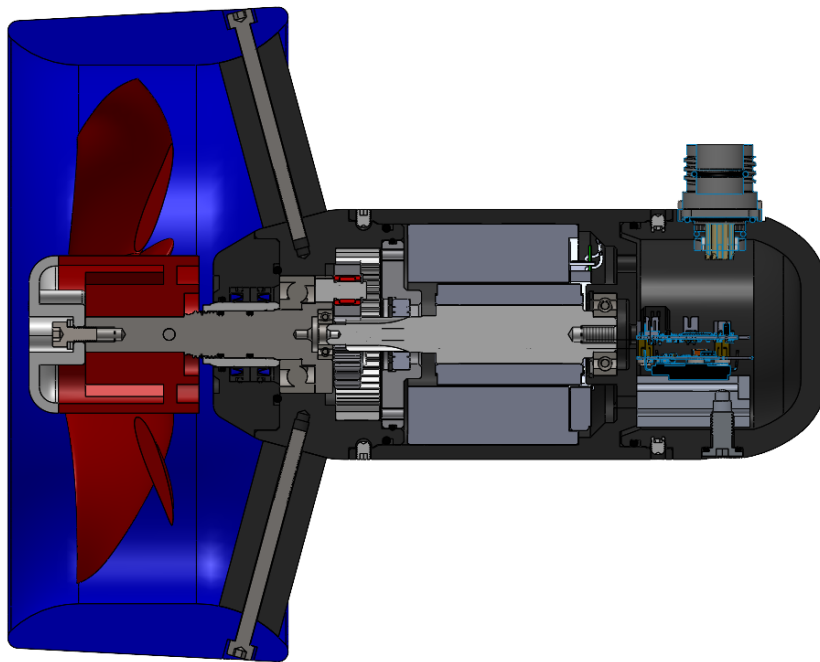

Figure 14 - DWT085G1 Thruster Sectional view

Table 6 - Tools list

Item No.	Part No.	Description	Qty
1	2J07-00002	Syringe + Silicone Grease set	1pcs
2	2P001-FLU5M4	M4 Allen Key	1pcs

7.3 Exploded View

ITEM No.	PART No.	TITLE	DESCRIPTION	QTY.
1	2C004-00085	Housing Assy	DWT085G1	1
2	2C004-00083	Reducer Assembly	DWT085G1	1
3	2C004-00100	End Cap Assy	MCG8M-FCR	1
4	2P001-D41N0M5-0806	Socket Grub Screw	M5xP0.8x6	8
5	2P005-SET0089	Vetus Propeller	BOW45/50/80 Propeller	1
6	2P001-W422M5A	Washer	SUS304 5.2x10x1	1
7	2P001-W4NWM5A	Washer	PE 5.2x10x1	1
8	2P001-D122M5-08010	Socket Head CAP Screw	SUS316 M5xP0.8x10	1
9	2D004-00051	Support Rod	DWT085G1	4
10	2D004-00058	Nozzle		1
11	2D013-00014	Socket Head CAP Screw	SUS316 M5xP0.8x80	4
12	2C004-00098	1500W Driver	1500W Driver	1

立體視圖

DWTEK CO., LTD
 No. 22 Dong Ying Rd.,
 Taichung City, Taiwan R.O.C
 Phone: 886 4 35024890
 Fax: 886 4 22112890
 E-mail: info@dwtek.com.tw

CATEGORY : Thruster DWT085G1
 PART No. 2B0040006-00004

Figure 15 - DWT085G1 Thruster (2B0040006-00004)

ITEM No.	PART No.	TITLE	DESCRIPTION	QTY.
1	2C004-00084	Shaft Reducer Assembly	K1401M-RS	1
2	2D004-00049	Gear Shaft Rotary Bush		1
3	2D004-00130	Constant Section Rings	ID13.5xW1.4x0.45	1
4	2C004-00043	Gear Motor Seal Cap Assy		1
5	2P001-D122M5-08010	Socket Head CAP Screw	SUS316 M5xP0.8x1.0	4

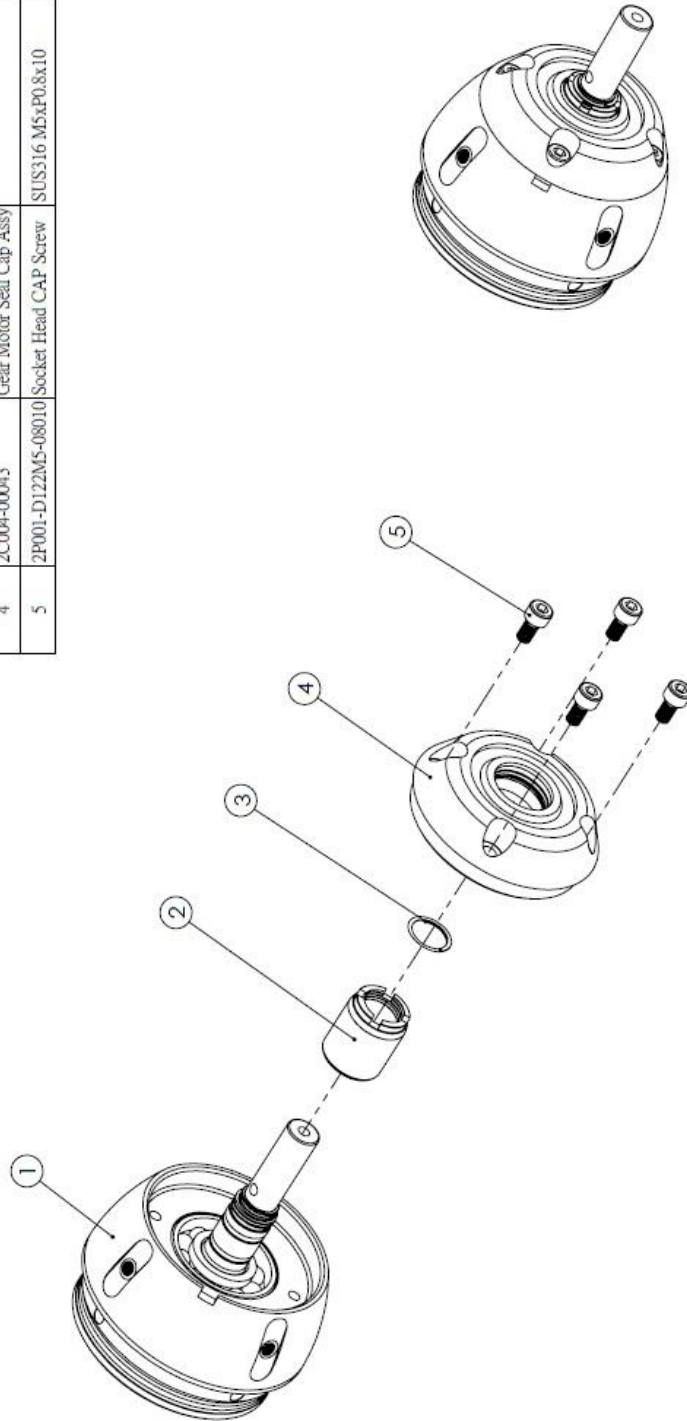

立體視圖

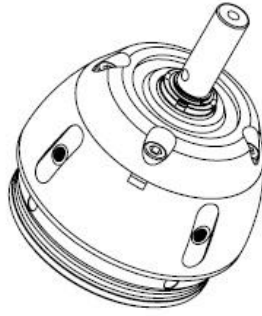

DWTEK CO., LTD
 No. 22 Dong Ying Rd.,
 Taichung City, Taiwan R.O.C
 Phone: 886 4 35024890
 Fax: 886 4 22112890
 E-mail: info@dwtek.com.tw



CATEGORY :
 Reducer Assembly
 PART No. 2C004-00083

Figure 16 - Reducer Assembly (2C004-00083)

ITEM No.	PART No.	TITLE	DESCRIPTION	QTY.
1	2D004-00147	Gear Box Fixture Plate	Oil Compensate	1
2	2P007-6901ZZNSK	Ball Bearing	OD24 x ID12 x 6	1
3	2P001-AR5524	Circlip	R24	1
4	2D004-00057	Inner Gear	1M 50T	1
5	2C004-00048	Planetary Carrier Assy		1
6	2P002-SOR-AS148N70	O-Ring	ID69.52 x W2.62	1
7	2D013-00013	Self-Tapping Inserts - Slotted	SUS304 M5xP0.8	4
8	2D004-00151	Motor Seal Cap	K1401M-RS	1
9	2P007-7203ZZKOYO	Ball Bearing	KOYO OD40xID17x12	1
10	2P002-SOR-AS014N70	O Ring	ID12.42 x W1.78	2

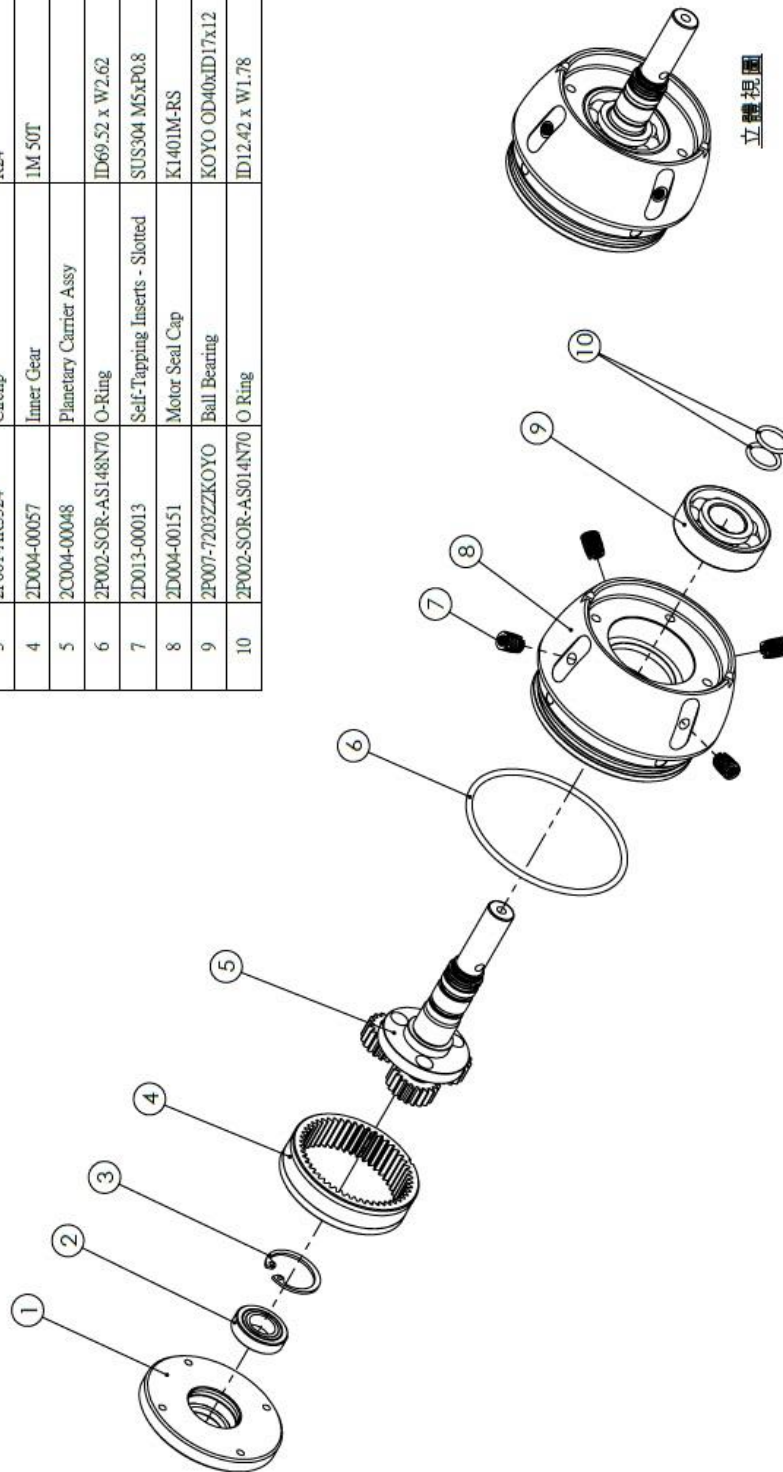

DWTEK CO., LTD
 No. 22 Dong Ying Rd,
 Taichung City, Taiwan R.O.C
 Phone: 886 4 35024890
 Fax: 886 4 22112890
 E-mail: info@dwtek.com.tw

立體視圖

CATEGORY :
 Shaft Reducer Assembly
 PART No. 2C004-00084

Figure 17 - Shaft Reducer Assembly (2C004-00084)

ITEM No.	PART No.	TITLE	DESCRIPTION	QTY.
1	2D004-00161	End Cap		1
2	2P002-SOR-AS149N70	AS-149	ID71.12 x W2.62	1
3	2D003-00016	Pressure relief valve	5/16"xT24	1
4	2P002-SOR-AS012N70	AS-012	ID9.25 x W1.78	2
5	2GM170308M-00001	Metal Shell G Flange Connector	MSC8M-FCR	1
6	2P001-D1B2M3-0508	Socket Head CAP Screw	SUS316 M3xP05x8	4
7	2D004-00158	Pressure relief valve	5/16"xT24	1

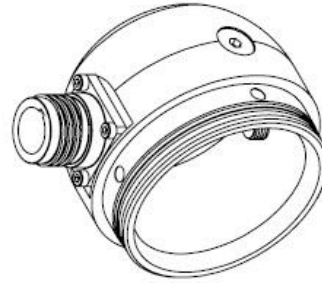
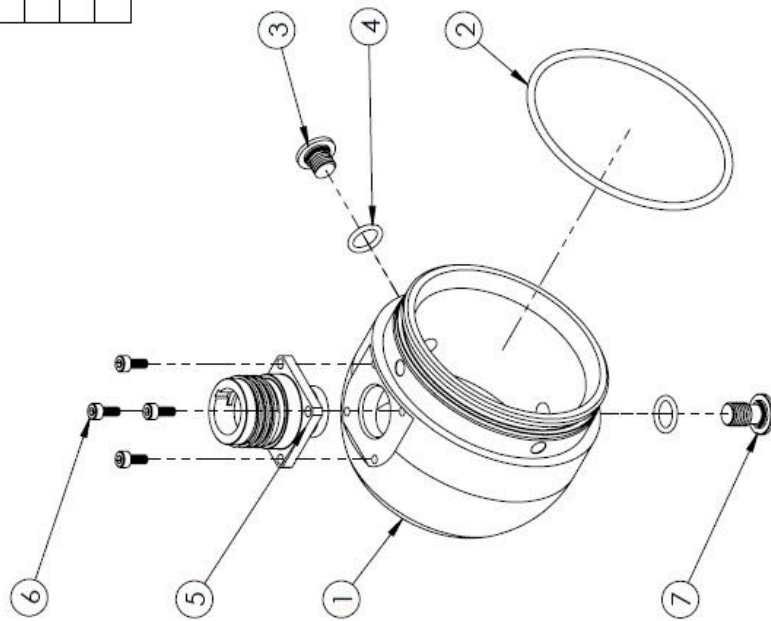

立體視圖

DWTEK CO., LTD
 No. 22 Dong Ying Rd.
 Taichung City Taiwan R.O.C
 Phone: 886 4 35024890
 Fax: 886 4 22112890
 E-mail: info@dwitek.com.tw

CATEGORY : End Cap Assy

PART No. 2C004-00100



Figure 18 - End Cap Assy (2C004-00100)



The information contained in this document is subject to be modified and/or supplemented from time to time by DWTEK Co., Ltd without prior notice.

DWTEK Co., Ltd shall not be liable for any loss, errors or damage in connection with information in this document.

Copyright © 2023 DWTEK Co., Ltd. All rights reserved.